

INSTRUCTION MANUAL FOR
DO-5510
DIGITAL OXYGEN METER



PLEASE READ THIS MANUAL CAREFULLY BEFORE OPERATION

ATTENTION :



Fill the Probe's Electrolyte at first.

Intend to keep the DO probe under the best condition, when user receive the DIGITAL OXYGEN METER along the PROBE, it should fill the the Probe's Electrolyte at first.

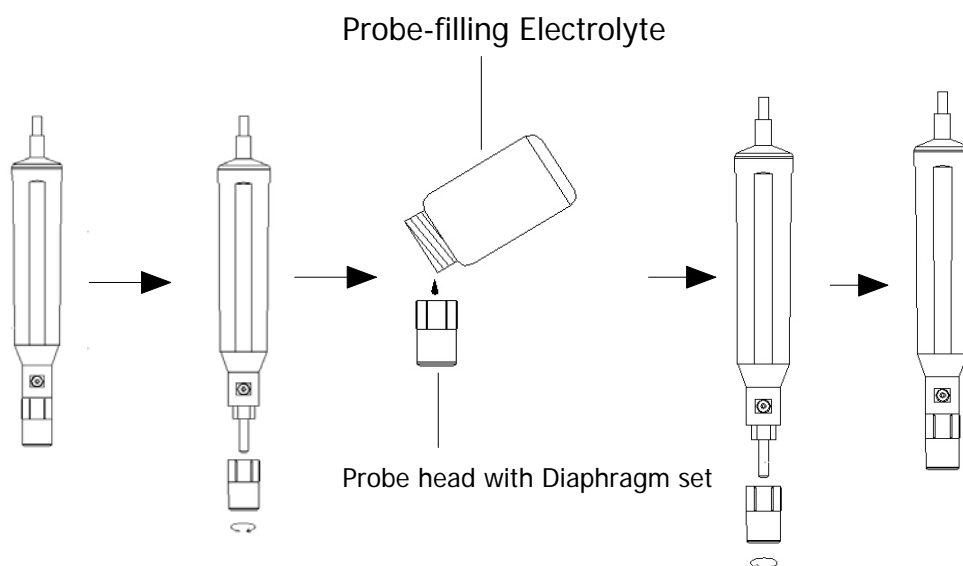

The procedures that to fill the Probe's Electrolyte, refer the chapter 8 " PROBE MAINTENANCE ", page 13 .

TABLE OF CONTENTS

1. GENERAL DESCRIPTIONS.....	1
2. FEATURES.....	1
3. SPECIFICATIONS.....	2
4. FRONT PANEL DESCRIPTION.....	4
4-1 Display.....	4
4-2 Power Off/On button.....	4
4-3 Data Hold button.....	4
4-4 °C/°F button.....	4
4-5 LCD Contrast Adjust VR.....	4
4-6 Memory Record button.....	4
4-7 Memory Call button.....	4
4-8 Factor Adj. button.....	4
4-9 Zero button.....	4
4-10 % Salt button.....	4
4-11 DO/O2 Selector.....	4
4-12 O2 Cal. button.....	4
4-13 MT. (Mountain Height) button.....	4
4-14 Battery Compartment/Cover.....	4
4-15 Probe Input Socket	4
4-16 RS-232 Output Terminal.....	4
4-17 Oxygen Probe handle.....	4
4-18 Temperature sensor.....	4
4-19 Probe head with diaphragm set.....	4
4-20 Protection cover for probe head.....	4
4-21 Oxygen probe plug.....	4
5. MEASURING PROCEDURE.....	5
5-1 Calibration.....	5
5-2 Dissolved Oxygen (DO) measurement	6
5-3 Oxygen in Air (O2) measurement	8
5-4 Temperature measurement	8
6. AUTO POWER OFF DISABLE and LCD CONTRAST ADJUSTMENT.....	11
7. RS232 PC SERIAL INTERFACE.....	12
8. PROBE MAINTENANCE.....	14
9. BATTERY REPLACEMENT.....	16

1. GENERAL DESCRIPTIONS

This Digital Oxygen Meter is supplied with a polarographic type probe with an incorporated Temp. sensor which serves for precise Dissolved Oxygen (DO) and Temp. measurement.

Applications for Aquarium, Medical research, Agriculture, Fish hatcheries, Laboratory, Water conditioning, Mining industry, Schools & Colleges, Quality control...

2. FEATURES

- * The polarographic type oxygen probe with an incorporated Temp. sensor, high precision measurement for Dissolved Oxygen (DO) and Temp. measurement.
- * Heavy duty dissolved oxygen probe, probe head can connect with BOD bottle
- * Automatic Temp. compensation from 0 to 50 °C for sensor.
- * Build in " % SALT " & " Mountain Height " compensation, adjust the factor by push the button on the front panel.
- * Microprocessor circuit assures high accuracy and provides special functions and features.
- * Super large LCD display with contrast adjustment for best viewing angle.
- * Multi-display, show oxygen & Temp. at the same time.
- * Records Maximum, Minimum and Average readings with recall, data hold.

- * Auto power off saves battery life.
- * Powered by 006P DC 9V battery.
- * RS 232 PC serial interface.
- * Build in temperature °C, °F measurement.
- * Use the durable, long-lasting components, including a heavy duty & compact ABS-plastic housing case.

3. SPECIFICATIONS

Circuit	Custom one-chip of microprocessor LSI circuit.	
Display	Dual function meter's display, 13 mm (0.5"). Super large LCD display with contrast adjustment for best viewing angle.	
Measurement & Range	Dissolved Oxygen	0 to 20.0 mg/L (liter).
	Oxygen in Air	0 to 100.0 %.
	Temperature	0 to 50 °C.
Resolution	Dissolved Oxygen	0.1 mg/L.
	Oxygen in Air	0.1 % O ₂ .
	Temperature	0.1 °C.
Accuracy (23± 5 °C)	Dissolved Oxygen	± 0.4 mg/L.
	Oxygen in Air	± 0.7% O ₂ .
	Temperature	± 0.8 °C/1.5 °F.
Sensor Structure	The polarographic type oxygen probe with an incorporated temperature sensor.	
Probe Compensation & Adj.	Temperature	0 to 50 °C , Automatic
	Salt	0 to 39 % Salt
	Height (M. T.)	0 to 3900 meter
Memory Recall	Records Maximum, Minimum and Average readings with recall.	

Power off	Auto power off saves battery life, or manual off by push button.
Data Output	RS 232 PC serial interface.
Over input indication	Indication of "- - - -".
Operating Temperature	0 °C to 50 °C (32 °F to 122 °F).
Operating Humidity	Max. 80% RH.
Sample Time	Approx. 0.4 sec.
Power Supply	006P DC 9V battery (Heavy duty type).
Power Current	Approx. DC 6.6 mA.
Weight	335 g/0.74 LB (batteries & probe included)
Size	Main instrument: 180 x 72 x 32 mm (7.1 x 2.8 x 1.3 inch).
	Oxygen probe : 190 mm x 28 mm Dia. (7.5" x 1.1" Dia.)
Accessories included	Oxygen probe(OXPB-11)..... 1 PC. Carrying case..... 1 PC. Operation manual..... 1 PC. Spare Probe head with Diaphragm OXHD-04.....2 set Probe-filling Electrolyte OXEL-03.....1 set
Optional Accessories	* Oxygen probe..... OXPB-11 * Spare Probe head with Diaphragm set OXHD-04 * Probe-filling Electrolyte..... OXEL-03 * RS232 cable..... UPCB-02 * USB cable..... USB-01 * Data Acquisition software SW-U801-WIN.

4. FRONT PANEL DESCRIPTION

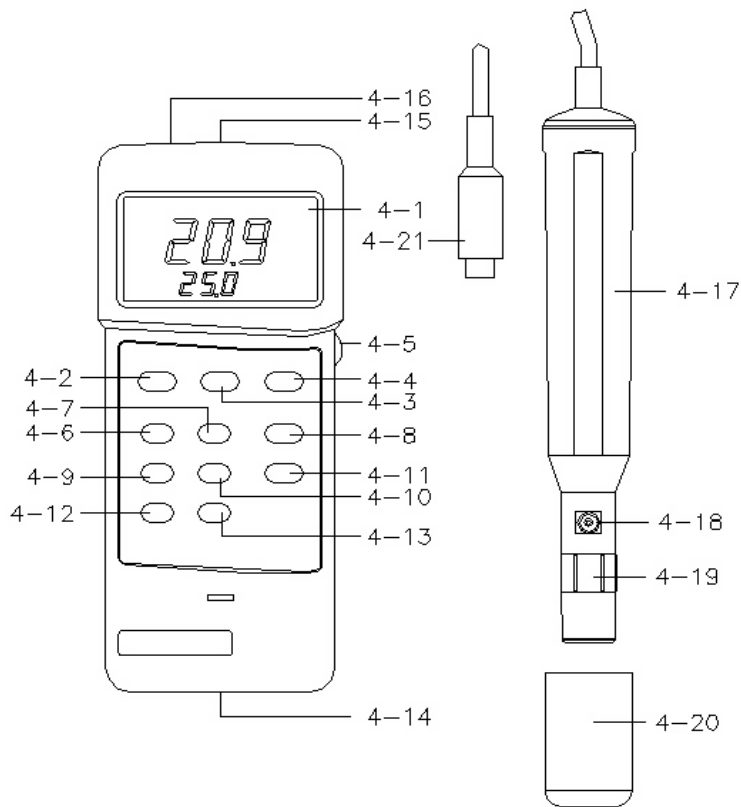

Fig. 1

- | | |
|----------------------------|--------------------------------------|
| 4-1 Display | 4-12 O2 Cal. button |
| 4-2 Power Off/On button | 4-13 MT. (Mountain Height) button |
| 4-3 Data Hold button | 4-14 Battery compartment/cover |
| 4-4 °C/ °F button | 4-15 Probe input socket |
| 4-5 LCD Contrast Adjust VR | 4-16 RS-232 input terminal |
| 4-6 Memory record button | 4-17 Oxygen Probe handle |
| 4-7 Memory call button | 4-18 Temperature sensor |
| 4-8 Factor Adj. button | 4-19 Probe head with diaphragm |
| 4-9 Zero button | 4-20 Protection cover for probe head |
| 4-10 % Salt button | 4-21 Oxygen probe plug |
| 4-11 DO/O2 selector | |

5 MEASURING PROCEDURE

5-1 Calibration

Before the measurement, the meter should be processed the following calibration procedures:

- 1) Disconnect the " OXYGEN PROBE plug " (4-21, Fig. 1) from the " Probe input socket " (4-15, Fig. 1).
- 2) Power on the instrument by pushing the " Power Off/On button " (4-2, Fig. 1).
- 3) Slide the " O2/DO selector " (4-11, Fig. 1) to the " O2 " position.
Push the " Zero button " (4-9, Fig. 1) and the display will show zero value.
- 4) Connect the " Oxygen probe plug " (4-21, Fig. 1) with the " Probe input socket " (4-15, Fig. 1). Wait for approx. 5 minutes at least until the display reading values become stable & no fluctuation. Push the " O2 Cal. button " (4-12, Fig. 1) and the display will show the values exactly same as 20.9 or 20.8. (As the oxygen in air is 20.9 % typically, so use the environment air O2 value for quick & precise calibration).

Calibration Consideration :

Please process calibration procedures under wide and ventilating environment for best effect.

5-2 Dissolved Oxygen (DO) measurement

- 1) After the meter be calibrated (above procedure 5-1), the meter is ready for DO measurement.
- 2) Slide the " O2/DO selector " (4-11, Fig. 1) to the " DO " position.
- 3) **"% Salt" compensation of the probe :**
 - a. Push the " % Salt button " (4-10, Fig. 1) first, and the display will show. :

0 %
S

- b. Push the " Factor Adj. button " (4-8, Fig. 1) once will add " 1 % " to the original salt % value until the adjusting reading reach the desired salt values. Then push the " % Salt button " (4-10, Fig. 1) again to finish the adjusting procedures. At this moment the new % salt values will be executed.
 - c. If the measured liquid is the pure water or the factor of salt % can be neglected, then adjust % salt compensation value to 0%.
- 4) **"Height" compensation of the probe :**

Bear in mind that the DO measurement is considered to be taken at sea level. However if the measuring environment is not at sea level (0 meter), then should adjust the " Height " values for the probe compensation when make the DO measurement.

- a. Push the " MT (Height) button " (5-13, Fig. 1) first, then the display will show

0
H

- b. Push the " Factor Adj. button " (4-8, Fig. 1) once will add " 100 meters " to the original height values until the adjusting reading reach the desired height values (meters). Then push the " MT (Height) button " (4-13, Fig. 1) again to finish the adjusting procedures. At this moment the new height values (display unit is the " meters ") will be executed.
- 5) a. Immersed the probe to a depth at least 10 cm of the measured liquid in order for the probe to be influenced by the temperature & automatic temperature compensation to take place.
- b. As for the thermal equilibrium to occur between the probe & the measurement sample must be allowed to pass, which usually amounts to a few minutes if the Temp. difference between the two is only several Celsius degrees.
- 6) a. In order to measure the dissolved oxygen content in any given liquid, it is sufficient to immerse the tip of the probe in the solution, making sure that velocity of the liquid coming into contact with the probe is at least 0.2 - 0.3 m/s or to shake the probe.
- b. During laboratory measurements, the use of a magnetic agitator to ensure a certain velocity in the fluid is recommended. In this way, errors due to the diffusion of the oxygen present in the air in the solution are reduced to a minimum.

7) Rinsed the probe accurately with normal tap water after each series of measurement.

5-3 Oxygen in Air (O₂) measurement

1) After the meter be calibrated (above procedure 5-1), now the meter is ready for O₂ measurement.

2) Slide the " O₂/DO selector " (4-11, Fig. 1) to the " O₂ " position.

3) The display will show the air oxygen in % values.

5-4 Temperature measurement

During the measurement, the lower LCD Display will show the temperature values of measuring solution.

* Push the " °C/°F button " (4-4, Fig. 1) once to select measuring unit in °C or °F.

5-5 Data Hold

During the measurement, Push the " Data Hold button " (4-3, Fig. 1) will hold the display values & LCD will show the " D.H " marker.

* Push the " Data Hold button " again will exit the data hold function.

5-6 Data Record(Max., Min., Average reading)

* The DATA RECORD function displays the maximum, minimum and average readings. To start the DATA RECORD function, press the " Memory Record button " (4-6, Fig. 1) once. " REC " symbol will appear on the LCD display.

- * With the " REC " symbol on the display :
- (a) Push the " Memory CALL button " (4-7, Fig. 1) once, the " Max " symbol along with the maximum value will appear on the display.
 - (b) Push the " Memory CALL button " again, the " Min " symbol along with the minimum value will appear on the display.
 - (c) Push the " Memory CALL button " again, the " AVG " symbol along with the average value will appear on the display.
 - (d) To exit the memory record function, push the " RECORD " button once again. The display will revert back to the current reading.

5-7 Quick operation procedures :

Calibration procedures

Power on, slide the " DO/O2 selector " to " O2 " position.



Disconnect the probe from the meter.
Push the " Zero button ", display will show zero.



Connect the probe to the meter. Until the display reading reach the stable values (approx. 5 minutes). Push the " O2 Cal. " position, then display will show 20.9.

Dissolved Oxygen (DO) measurement procedures

Power on, after calibration procedures be executed.



Slide the " DO/O2 selector " to " DO " position.



Determine the " % Salt " & " Height " values.

** For the general application, it is not necessary to make the adjustment for the " % salt " & " Height " values.*



Immerse the probe head into the measured liquid.

Other function :

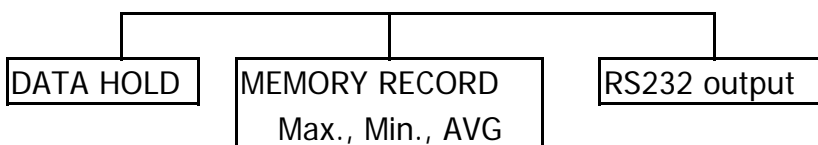

Power management

AUTO POWER OFF or MANUAL POWER OFF

Not available in

Memory Record function

6. AUTO POWER OFF DISABLE and LCD CONTRAST ADJUST

- 1) The instrument has built-in "Auto Power off " in order to prolong battery life. The meter will switch off automatically if none of the buttons are pressed within 10 min.
To de-activate this feature, select the memory record function during measurement by pressing the " RECORD " button (4-6, Fig. 1).
- 2) The instrument also features the ability to adjust the contrast of the display.
This is achieved by controlling the " LCD Contrast Adjust " pot (4-5, Fig. 1).

7. RS232 PC SERIAL INTERFACE

The instrument features an RS232 output via 3.5 mm Terminal (4-16, Fig. 1). The connector output is a 16 digit data stream which can be utilized to the user's specific application.

An RS232 lead with the following connection will be required to link the instrument with the PC serial input.

Meter (3.5 mm jack plug)	PC (9W 'D" Connector)
Center Pin.....	Pin 2
Ground/shield.....	Pin 5

The 16 digit data stream will be displayed in the following format :

D15 D14 D13 D12 D11 D10 D9 D8 D7 D6 D5 D4 D3 D2 D1 D0

Each digit indicate the following status :

D15	Start Word =02		
D14	Reading Polarity for the Display.		
	0 = Both upper & lower display value are "+".		
	1 = Upper "-", Lower "+".		
	2 = Upper "+", Lower "-".		
D13	Anunciator for Lower Display		
	0 =No Symbol	1 :°C	2 = °F
D12 & D11	Anunciator for Upper Display		
	01 :°C	07 = mg/L	
	02 :°F	06 = % O2	
D10	Decimal Point (DP) for lower display 0 = No DP, 1= 1 DP, 2 = 2 DP, 3 = 3 DP		
D9	Decimal Point (DP) for Upper display. 0 = No DP, 1= 1 DP, 2 = 2 DP, 3 = 3 DP		
D8 to D5	Lower Display reading, D5=LSD, D8=MSD		
D4 to D1	Upper Display reading, D1=LSD, D4=MSD		
D0	End Word = 0D		

RS232 setting

Baud rate	9600
Parity	No parity
Data bit no.	8 Data bits
Stop bit	1 Stop bit

8. PROBE MAINTENANCE

User first time to use the meter :

Intend to let the DO probe keep the best condition. When user receive the DIGITAL OXYGEN METER along the PROBE, it should fill the Probe's Electrolyte at first.

User already use the meter for a certain period :

Whenever user can not calibrate the meter properly or the meter's reading value is not stable, please check the oxygen probe to see if the electrolyte in the probe head container is run out or the diaphragm (probe head with diaphragm set) exist problem (dirty). If yes, please fill the electrolyte or change the " Probe head with diaphragm set " and make the new calibration.

The consideration of Diaphragm (probe head with diaphragm set) :

The oxygen probe component is the thin Teflon diaphragm housed in the tip of the probe. The diaphragm is permeable by the oxygen molecules but not by the considerably larger molecules contained in the electrolyte. Due to this characteristic, the oxygen may diffuse throughout the electrolyte solution contained in the probe, and its concentration may be quantified by the measurement circuit.

This sensitive diaphragm is rather delicate & is easily damaged if it comes into contact with solid objects or is subjected to blows. If the diaphragm is damaged or the electrolyte is run out, it must be replaced in the following way :

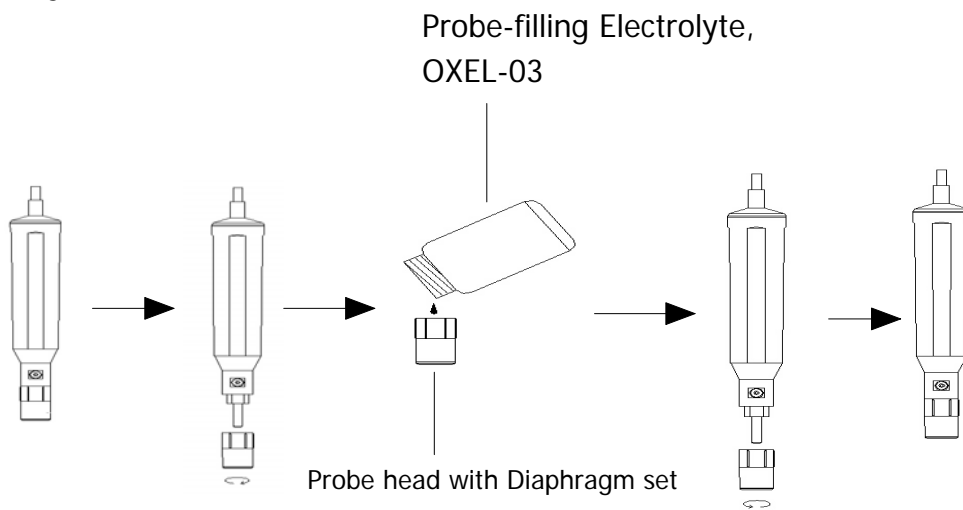

- 1) Unscrew the " Probe head " (8-3, Fig 2).
- 2) Pour out the old Electrolyte from the container of the " Probe head " .
- 3) Fill the new Electrolyte (OXEL-03) into the container of the " Probe head " .
- 4) Screw the " Probe head " (8-3, Fig 2) into the probe body.

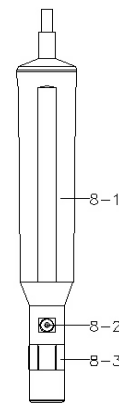

Fig. 2

- 8-1 Probe handle
- 8-2 Temp. sensing metal
- 8-3 Probe head

9. BATTERY REPLACEMENT

- 1) When the left corner of LCD display show " LBT ", it is necessary to replace the battery. However, in-spec measurement may still be made for several hours after low battery indicator appears.
- 2) Slide the " Battery Cover " (4-14, Fig. 1) away from the instrument and remove the battery.
- 3) Replace with 9V battery (heavy duty type) and reinstate the cover.
- 4) Make sure the battery cover is secured after changing the battery.