

HIOKI

INSTRUCTION MANUAL

3256-50

3256-51

DIGITAL HiTESTER

HIOKI E. E. CORPORATION

Contents

Introduction	1
Inspection	1
Safety Notes	2
Usage Notes	6
Chapter 1 Overview	9
1.1 Product Overview	9
1.2 Features	9
1.3 Parts Names and Functions	10
Chapter 2 Measurement Procedures	15
2.1 Voltage Measurement.....	16
2.2 Frequency Measurement.....	18
2.3 Current Measurement.....	19
2.4 Resistance Measurement.....	22
2.5 Continuity Check.....	23
2.6 Diode Check	24
Chapter 3 Additional Functions	25
3.1 HOLD AUTO Function	25
3.2 HOLD Function	26
3.3 Overflow Warning Function	27
3.4 Relative Display Function	28
3.5 Auto Power Save Function	30
3.6 Voltage Detecting Function	31
3.7 Dynamic Recording Function	32
3.8 Memory Function	33

Chapter 4 Specifications 35

4.1	General Specifications	35
4.2	Accuracy	39

Chapter 5 Maintenance and Service 43

5.1	Replacing the Batteries and Fuses	43
5.2	Cleaning	45
5.3	Service	45

Introduction

Thank you for purchasing the HIOKI "3256-50/51 DIGITAL HiTESTER". To obtain maximum performance from the product, please read this manual first, and keep it handy for future reference.

Inspection

- When you receive the product, inspect it carefully to ensure that no damage occurred during shipping. In particular, check the accessories, panel switches, and connectors. If damage is evident, or if it fails to operate according to the specifications, contact your dealer or Hioki representative.
- Before using the product the first time, verify that it operates normally to ensure that no damage occurred during storage or shipping. If you find any damage, contact your dealer or Hioki representative.
- Before using the product, make sure that the insulation on the test leads is undamaged and that no bare conductors are improperly exposed. Using the product under such conditions could result in electrocution. Replace the test leads and probes with the specified Hioki Model 9207-10.

Accessories



◀ 3256-50 *1



▼ 3256-51 *2

9207-10 TEST LEAD	1
Instruction Manual.....	1
R03 Manganese battery.....	2
(Supplied with this product, for monitor)	
9378 CARRYING CASE *1	
(3256-50 only)	
Protective holster *2	(3256-51 only)











Safety Notes

This manual contains information and warnings essential for safe operation of the product and for maintaining it in safe operating condition. Before using the product, be sure to carefully read the following safety notes.



! DANGER

This product is designed to conform to IEC 61010 Safety Standards, and has been thoroughly tested for safety prior to shipment. However, mishandling during use could result in injury or death, as well as damage to the product. Be certain that you understand the instructions and precautions in the manual before use. We disclaim any responsibility for accidents or injuries not resulting directly from product defects.



Safety Symbols

	<p>In the manual, the  symbol indicates particularly important information that the user should read before using the product.</p>
	<p>The  symbol printed on the product indicates that the user should refer to a corresponding topic in the manual (marked with the  symbol) before using the relevant function.</p>
	<p>Indicates that dangerous voltage may be present at this terminal.</p>
	<p>Indicates a double-insulated device.</p>
	<p>Indicates a grounding terminal.</p>
	<p>Indicates DC (Direct Current).</p>
	<p>Indicates AC (Alternating Current).</p>
	<p>Indicates DC (Direct Current) or AC (Alternating Current).</p>

The following symbols in this manual indicate the relative importance of cautions and warnings.

 DANGER	Indicates that incorrect operation presents an extreme hazard that could result in serious injury or death to the user.
 WARNING	Indicates that incorrect operation presents a significant hazard that could result in serious injury or death to the user.
 CAUTION	Indicates that incorrect operation presents a possibility of injury to the user or damage to the product.
NOTE	Advisory items related to performance or correct operation of the product.

Other Symbols

	Indicates the quick guide for operations
	Indicates the prohibited action
	Indicates the reference

Accuracy

We define measurement tolerances in terms of f.s. (full scale), rdg. (reading) and dgt. (digit) values, with the following meanings:

f.s.	(maximum display value or scale length) The maximum displayable value or the full length of the scale. This is usually the maximum value of the currently selected range.
rdg.	(reading or displayed value) The value currently being measured and indicated on the measuring product.
dgt.	(resolution) The smallest displayable unit on a digital measuring product, i.e., the input value that causes the digital display to show a "1".

Measurement categories (Overvoltage categories)

This product complies with CATIII (600 V), CATII (1000 V) safety requirements.

To ensure safe operation of measurement products, IEC 61010 establishes safety standards for various electrical environments, categorized as CAT I to CAT IV, and called measurement categories. These are defined as follows.

- CAT I Secondary electrical circuits connected to an AC electrical outlet through a transformer or similar device.
- CAT II Primary electrical circuits in equipment connected to an AC electrical outlet by a power cord (portable tools, household appliances, etc.)
- CAT III Primary electrical circuits of heavy equipment (fixed installations) connected directly to the distribution panel, and feeders from the distribution panel to outlets.
- CAT IV The circuit from the service drop to the service entrance, and to the power meter and primary overcurrent protection device (distribution panel).

Higher-numbered categories correspond to electrical environments with greater momentary energy. So a measurement device designed for CAT III environments can endure greater momentary energy than a device designed for CAT II.

Using a measurement product in an environment designated with a higher-numbered category than that for which the product is rated could result in a severe accident, and must be carefully avoided.

Never use a CAT I measuring product in CAT II, III, or IV environments.

The measurement categories comply with the Overvoltage Categories of the IEC60664 Standards.

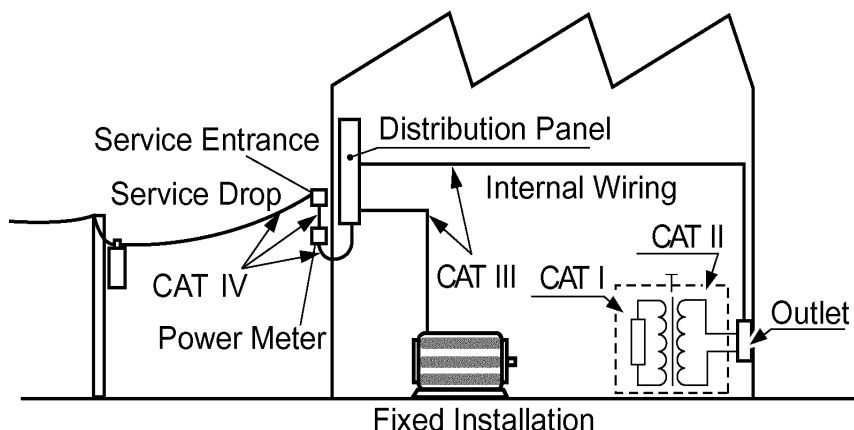

Usage Notes



Follow these precautions to ensure safe operation and to obtain the full benefits of the various functions.

WARNING



- To avoid electric shock, do not allow the product to get wet, and do not use it when your hands are wet.
- Do not use the product where it may be exposed to corrosive or combustible gases. The product may be damaged or cause an explosion.

! CAUTION

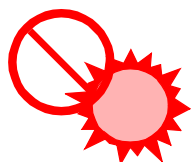

Direct
sunlight

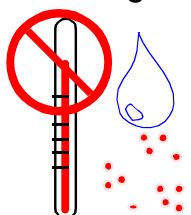

High temper-
ature, high
humidity, dust



Electromag-
netic radiation



Impact,
dropping

Observe the following to avoid damage to the product.

- Installation and Operating Environment
Between 0°C and 40°C; 80% RH or less; indoors only. However, it can be safely operated at as low as -10°C.
- Do not store or use the product where it could be exposed to direct sunlight, high temperature or humidity, or condensation. Under such conditions, the product may be damaged and insulation may deteriorate so that it no longer meets specifications.
- This product is not designed to be entirely water- or dust-proof. To avoid damage, do not use it in a wet or dusty environment.
- Do not use the product near a device that generates a strong electromagnetic field or electrostatic charge, as these may cause erroneous measurements.
- To avoid damage to the product, protect it from vibration or shock during transport and handling, and be especially careful to avoid dropping.
- Adjustments and repairs should be made only by technically qualified personnel.
- If the protective functions of the product are damaged, either remove it from service or mark it clearly so that others do not use it inadvertently.
- To avoid corrosion from battery leakage, remove the batteries from the product if it is to be stored for a long time.

NOTE

- Accurate measurement may be impossible in the presence of strong magnetic fields, such as near transformers and high-current conductors, or in the presence of strong electromagnetic fields such as near radio transmitters.
- To avoid battery depletion, turn the function selector OFF after use (the Auto Power Save feature consumes a small amount of current).
- The **B** indicator appears when battery voltage becomes low. Replace the batteries as soon as possible.

Overview

Chapter 1

1.1 Product Overview

This measurement product is a multi-functional digital multimeter capable of measuring DC and AC voltages, DC and AC currents, and the resistance, checking the diode and continuity, and detecting voltage.

1.2 Features

- ◆ **Compliance with CE marking requirements**
The measurement product is designed to comply with the international safety standard (IEC61010-1) and EMC standards.
- ◆ **Safety-designed handy digital multimeter**
The measurement product is equipped with test-lead misinsertion preventive shutters and fast-acting fuses at the current measurement terminals.
- ◆ **Multi-functional and voltage detecting**
 - Live conductors can be examined safely and easily.
 - The Hold Auto function allows measured values to be maintained by simply disconnecting the test leads.
 - The Hold function maintains the displayed value.
 - The Memory function saves the held value displayed.
 - The Recording function displays the maximum, minimum, average, and currently measured values selectively.
 - The Relative function displays any discrepancy from the reference.

1.3 Parts Names and Functions

*: for details, see the following pages

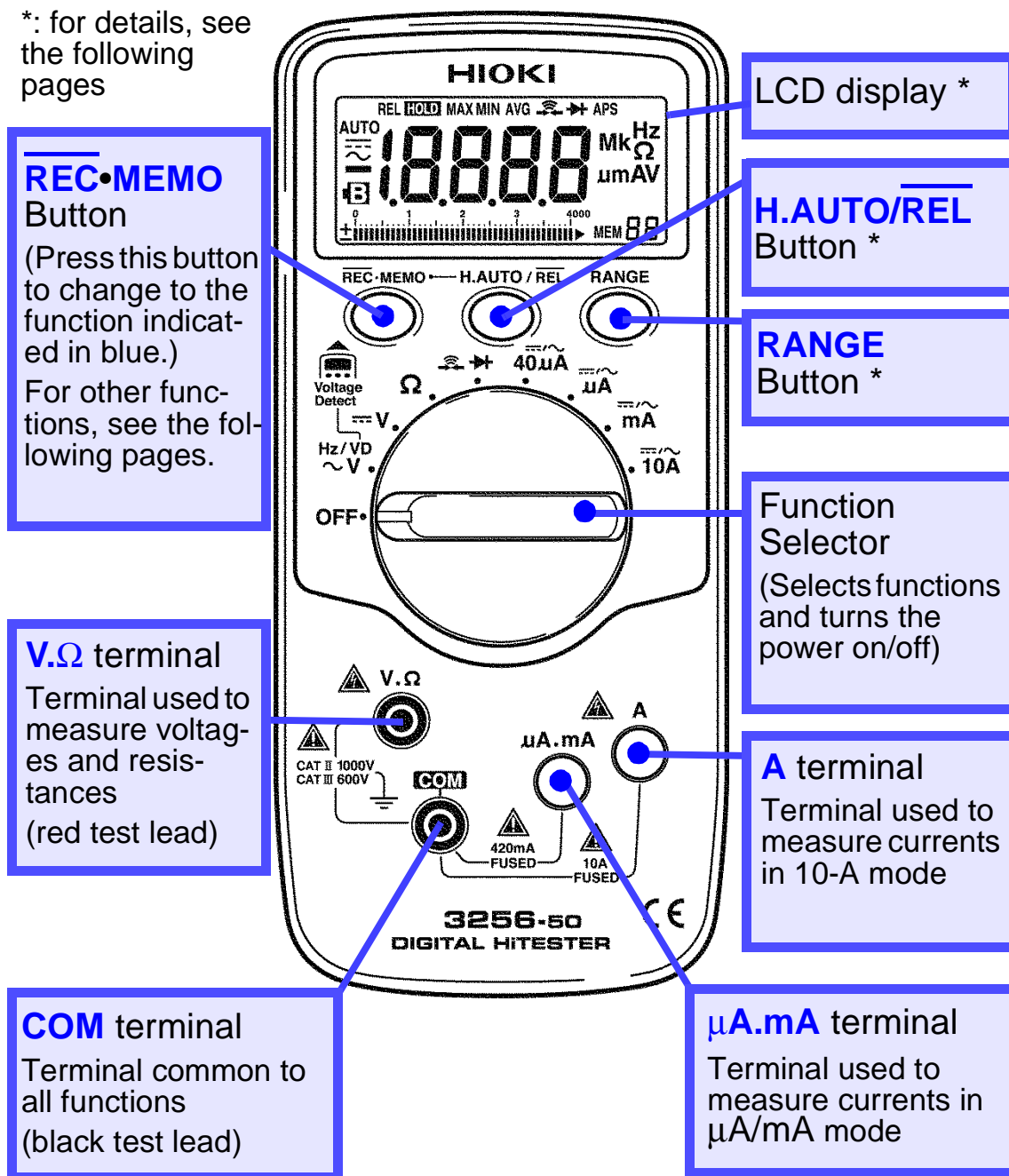

NOTE

The terminal shutter works together with the function selector to prevent incorrect operation. Note that if the function selector is toggled with the test leads connected, the measurement product may be damaged.

LCD(Display)

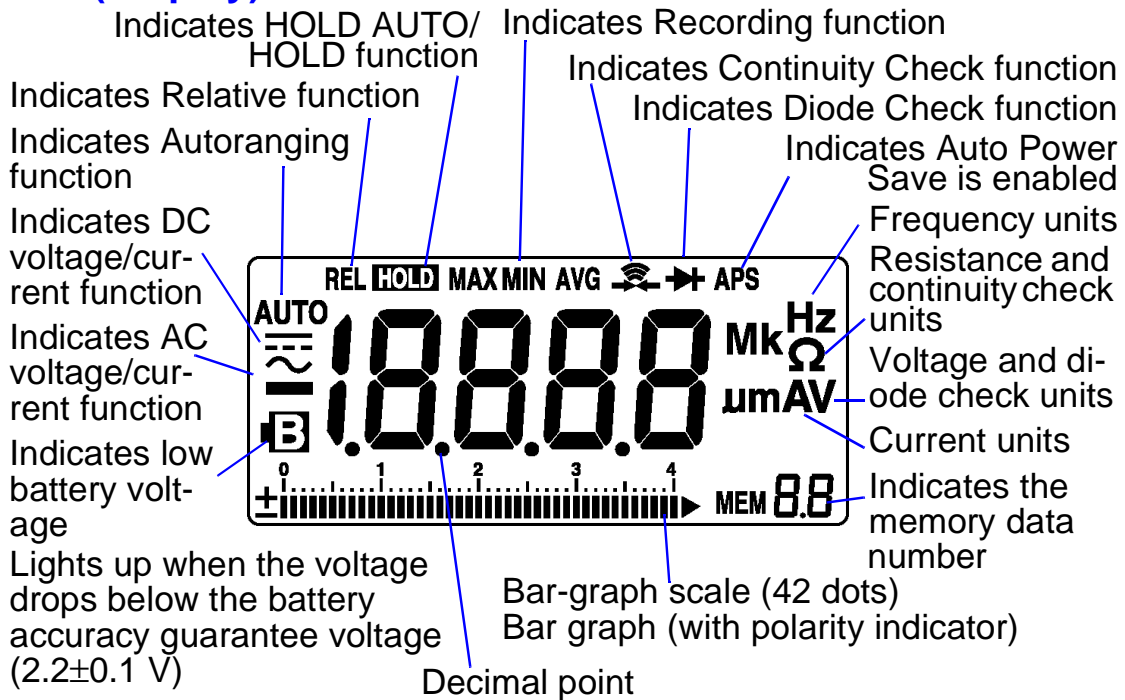

REC•MEMO

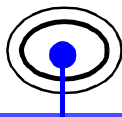

Changes to the function indicated in blue
 Toggles between AC and DC modes (Current measurement) ❖ (page 19)
 Recording function (Displays MAX/MIN/AVG)*1 ❖ (page 32)
 Voltage Detecting ❖ (page 31)
 Memory Function ❖ (page 33)
 Cancels the Auto Power Save function *2 ❖ (page 30)

H.AUTO/REL

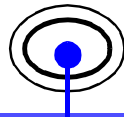

HOLD AUTO function (Holds the measured value) ❖ (page 25)
 Turns the HOLD function on/off *2 ❖ (page 26)
 Turns the Relative function (displaying the relative value) on/off*1 ❖ (page 28)

RANGE

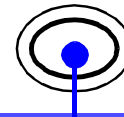

Changes the manual range and selects range
 Changes the auto range from the manual range*1
 Changes the input level (Frequency function) ❖ (page 18)
 Calls data from memory*2 ❖ (page 34)

*1: Press the button for at least 1 second (REC and REL require the button to be pressed for a longer time).
 *2: Turn on the power while pressing the button, and hold the button down until a beeping sound is generated (power-on option).

Function Selector

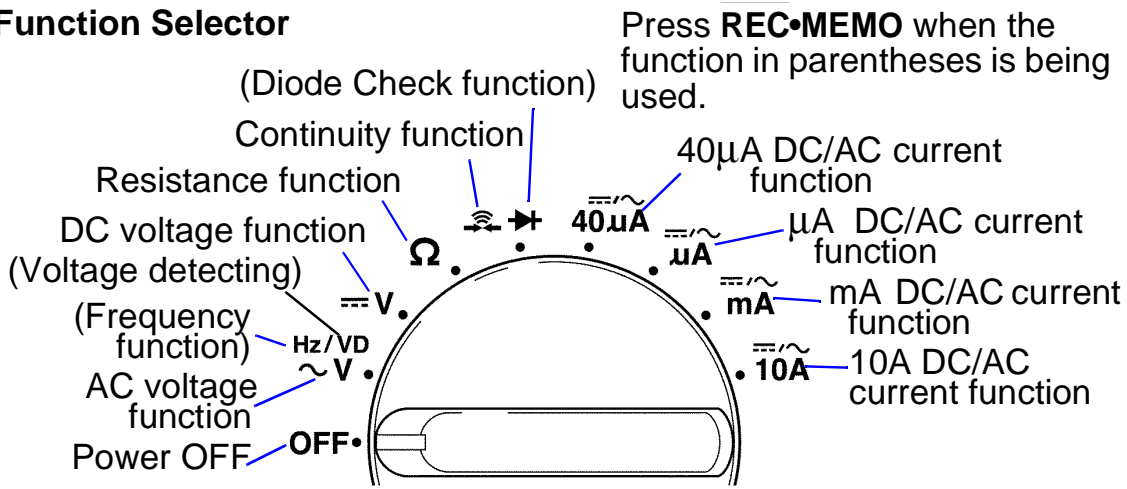

Quick Reference			
Measurements	Operations		(page)
AC voltage	$\sim V$ — (V.Ω) COM —> Measurement		16
DC voltage	$\equiv V$ — (V.Ω) COM —> Measurement		16
DC/AC Current (40 µA)	\equiv/\sim 40µA — REC•MEMO (\equiv/\sim) — µA.mA COM —> Measurement	Example Switches between measurement to display in parentheses.	20
DC/AC Current (400/4000 µA)	\equiv/\sim µA — REC•MEMO (\equiv/\sim) — µA.mA COM —> Measurement		20
DC/AC Current (40/400 mA)	\equiv/\sim mA — REC•MEMO (\equiv/\sim) — µA.mA COM —> Measurement		21
DC/AC Current (10A)	\equiv/\sim 10A — REC•MEMO (\equiv/\sim) — A COM —> Measurement		21
Resistance	Ω — (V.Ω) COM —> Measurement		22
Continuity	\rightarrow — REC•MEMO (\rightarrow) — (V.Ω) COM —> Measurement		23
Diode	\rightarrow — REC•MEMO (\rightarrow) — (V.Ω) COM —> Measurement		24

Frequency		18
Voltage detecting		31

Quick Reference (application)		
<p>REC-MEMO Button</p> <p>REC-MEMO + : Turn on the power while pressing the button (hold the button down until a beeping sound is generated).</p> <p><1 second: Press the button for at least 1 second.</p>	Example	
<p>Hold the measured value. (HOLD AUTO function)</p> <p>This function is used when the displayed value cannot be checked during measurement (such as when necessary to measure the conductor in a dark place or using both hands).</p>		
<p>~V/Ω/40μA/μA/mA/10A</p> <p>H.AUTO/REL</p> <p>"HOLD" Blinking (Intermittent sound)</p> <p>Move the test leads away from the measurement object.</p>		25
<p>Hold the measured value. (HOLD function)</p>		
<p>~V/Ω/V/Hz/Ω/μA/mA/10A</p> <p>H.AUTO/REL</p> <p>Measurement</p>		26
<p>"O.F" is displayed to provide a warning (Overflow Warning function)</p>		
<p>~V/Ω/V/40μA/μA/mA/10A</p> <p>When the measured value exceeds the maximum value, "O.F" is displayed.</p>		27
<p>Use this function to check any discrepancy from the reference, or to control the resistance for the purpose of zero adjustment (Relative function)</p>		
<p>~V/Ω/40μA/μA/mA/10A</p> <p>Display the reference. (H.AUTO/REL) ("REL" lights up)</p> <p>Cancellation: H.AUTO/REL (press again)</p>		28

Cancel the Auto-Power Save function.

(Auto-Power Save function)

~V/Ω V/Hz/
VD/Ω/Ω/→/→/
40μA/μA/mA/
10A

REC•MEMO



Press this button until a beeping sound is generated.

Enable the Power Save function:

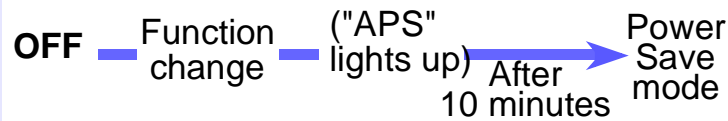

30

Check the maximum, minimum, and average values during measurement.

(Recording function)

~V/Ω V/Ω/
40μA/μA/mA/
10A

REC•MEMO

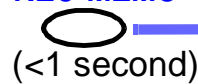

("MAX MIN AVG" lights up)

H.AUTO/REL



(<1 second) (MAX MIN AVG)
MAX:maximum value/ MIN:minimum value/
AVG:average value/ MAX MIN AVG: Current value
Cancellation: REC•MEMO (press again)

32

Save the measured value to memory.

(Memory function)

~V/Ω V/Ω/
40μA/μA/mA/
10A

Hold the displayed value

REC•MEMO



("MEM." lights up)

H.AUTO/REL

33

Call the saved data.

~V/Ω V/Ω/
40μA/μA/mA/
10A

RANGE



Memory-data display

RANGE



Select MEM#.

34

Delete all data from memory.

~V/Ω V/Ω/
40μA/μA/mA/
10A

RANGE



REC•MEMO

RANGE



(<1 second)

34

Measurement Procedures

Chapter 2

DANGER

Observe the following precautions to avoid electric shock.

- Always verify the appropriate setting of the function selector before connecting the test leads.
- Disconnect the test leads from the measurement object before switching the function selector.
- When it is necessary to replace the measurement terminal, remove the test lead from the measurement object and disconnect the lead from the terminal before toggling the function selector.

WARNING

Even when the shutter is closed, the terminals are not sufficiently separated. To avoid electrocution, do not touch the terminals.

NOTE

When the shutter is damaged, discontinue measurement and repair it.

2.1 Voltage Measurement



! DANGER

- The maximum input voltage is 1000 VDC, 1000 Vrms, or $10^7 \text{V}\cdot\text{Hz}$. However, for CATIII circuits, the maximum voltage is 600 Vrms. Attempting to measure voltage in excess of the maximum input could destroy the product and result in personal injury or death.
- To avoid electrical shock, be careful to avoid shorting live lines with the test leads.
- For safety, test lead connections must always be made at the secondary side of a circuit breaker.
- The maximum rated voltage between input terminals and ground is 1000 V DC/AC (CATII), 600 V DC/AC (CATIII), or $10^7 \text{V}\cdot\text{Hz}$. Attempting to measure voltages exceeding this limit with respect to ground could damage the product and result in personal injury.

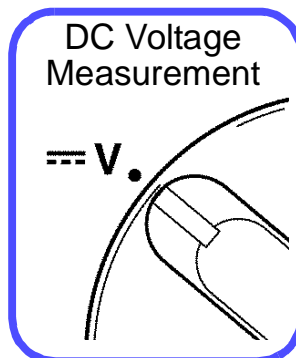
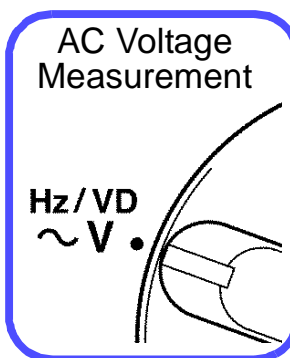

1. Move the function selector to the $\sim \text{V}$ position for AC mode or to the $\text{—} \text{V}$ position for DC mode (in either case, "V" lights up).

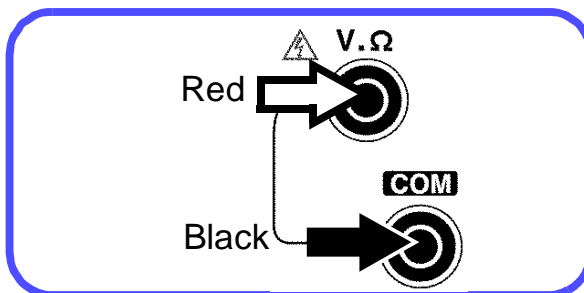

2. Connect the red test lead to terminal $\text{V}\cdot\Omega$, and the black test lead to terminal **COM**.

AC Voltage Measurement

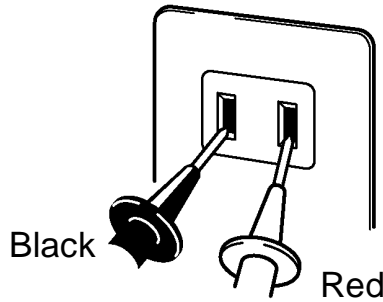

DC Voltage Measurement

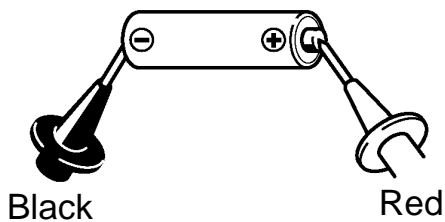

- 3.** Connect the test leads to the measurement object, and read the indicated value.

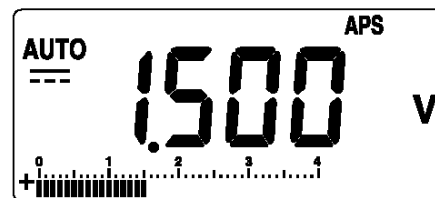

Selecting the manual range:
Reselecting the auto range:

Holding the measured value:
❖ HOLD AUTO Function, page 25) or
❖ HOLD Function, page 26)

Appearance of O.F:

Press **RANGE** ("AUTO" is turned off)
Press **RANGE** (for at least 1 second) ("AUTO" lights up)

Press **H.AUTO/REL** → Measurement → Intermittent sound → Move the test leads away from the measurement object.

Press **H.AUTO/REL**+Power-on → Measurement → Press **H.AUTO/REL**

The measured value exceeds 4200 counts (up to the 420-V range) or 1050 counts (1000-V range).

NOTE

The indicated value may vary due to the existence of induced voltage under no-power conditions. However, this is not a problem.

2.2 Frequency Measurement



! DANGER

- The maximum input voltage is 1000 VDC, 1000 Vrms, or $10^7 \text{V}\cdot\text{Hz}$. However, for CATIII circuits, the maximum voltage is 600 Vrms. Attempting to measure voltage in excess of the maximum input could destroy the product and result in personal injury or death.
- For safety, test lead connections must always be made at the secondary side of a circuit breaker.

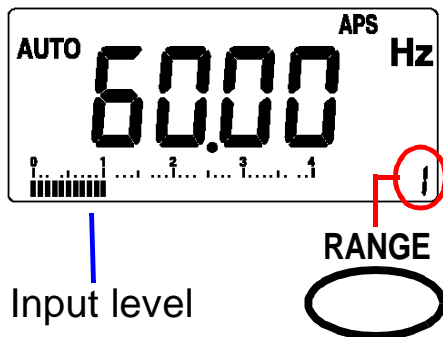
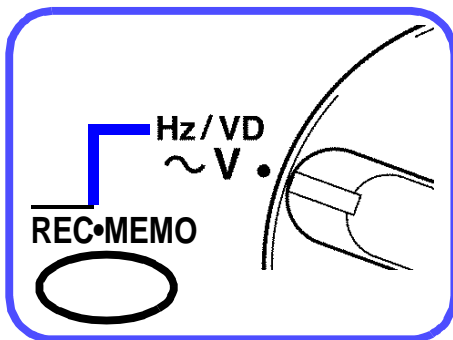

Input level

Attenuation factor of the input voltage ($1/10^n$)
(n: Scale number)
Indication range: 0.5 Hz to 500 kHz

1. Move the function selector to the $\sim\text{V}$ position and press the **REC•MEMO** button ("Hz" lights up).
2. Connect the red test lead to terminal **V.Ω**, and the black test lead to terminal **COM**.
3. Select the input level (1 to 4) using the **RANGE** button, in accordance with the input voltage.
4. Connect the test leads to the measurement object, and read the indicated value.

	Input level	Range
1	0.8 to 4 V	4.200V
2	4 to 40	42.00V
3	40 to 400 V	420.0V
4	400 to 1000V	1000V



Canceling the frequency measurement:

Press **REC•MEMO**

2.3 Current Measurement



DANGER

- Never apply voltage to the test leads when a current measurement function is selected. Doing so may damage the product and result in personal injury.
- To avoid electrical accidents, remove power from the circuit before connecting the test leads.

WARNING

- To avoid electrical shock, do not use the product to measure current in circuits of 600 V or greater. The current function overload protection trips at 600 Vrms.
- Maximum input current in each range
 40 μ A/ μ A/mA range: 420mADC/ 420 mA rms
 10A range: 10 ADC/ 10 A rms
 Do not input a current in excess of this value. Otherwise, the measurement product will be damaged, resulting in an accident that may cause injury or death.



Selecting the manual range: Press **RANGE**

("AUTO" is turned off)

Reselecting the auto range: Press **RANGE** (for at least 1 second) ("AUTO" lights up)

Holding the measured value:

❖ HOLD AUTO Function, page 25) or

❖ HOLD Function, page 26)

Press **H.AUTO/REL** → Measurement → Intermittent sound → Move the test leads away from the measurement object.

Press **H.AUTO/REL**+Power-on → Measurement → **H.AUTO/REL**

Appearance of O.F:

The measured value exceeds 1050 counts(10-A range) or 4200 counts (other ranges).

40 μ A Measurement (42 μ A range)

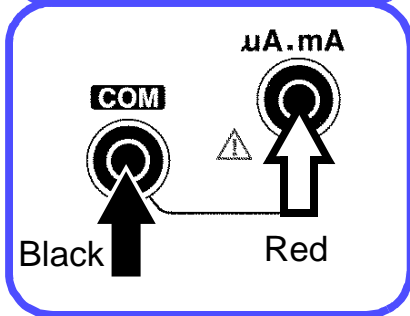
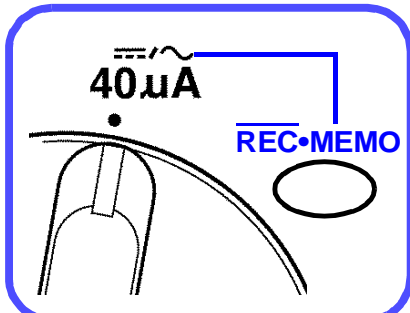

1. Move the function selector to the **40 μ A** position.
2. Select DC (≡) or AC (∩) using the **REC•MEMO** button.
3. Connect the red test lead to terminal **μ A.mA**, and the black test lead to terminal **COM**.
4. Connect the test leads to the measurement object, and read the indicated value.
The Auto Range function is not provided.

μ A Measurement (420 μ A/4200 μ A range)

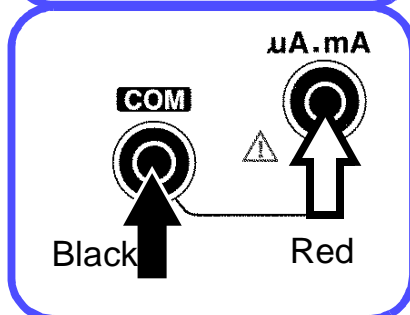
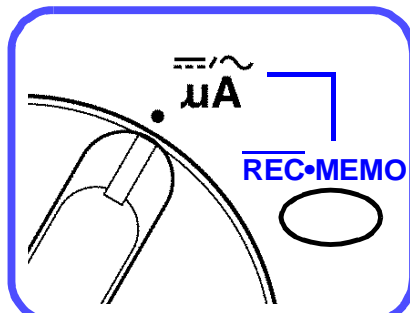

1. Move the function selector to the **μ A** position.
2. Select DC (≡) or AC (∩) using the **REC•MEMO** button.
3. Connect the red test lead to terminal **μ A.mA**, and the black test lead to terminal **COM**.
4. Connect the test leads to the measurement object, and read the indicated value.

mA Measurement (40 mA/400 mA)

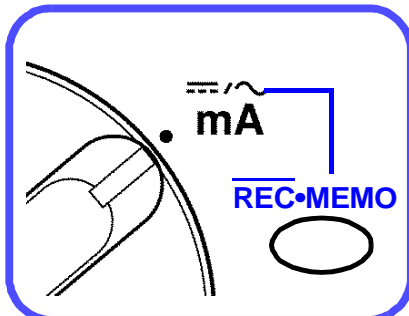

1. Move the function selector to the **mA** position.
2. Select **DC** (—) or **AC** (～) using the **REC•MEMO** button.

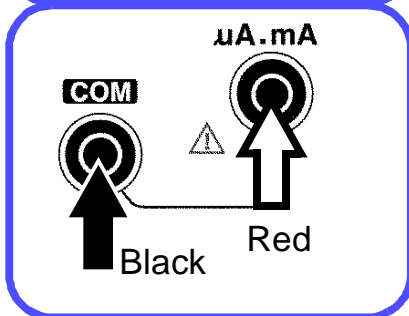

3. Connect the red test lead to terminal **uA.mA**, and the black test lead to terminal **COM**.
4. Connect the test leads to the measurement object, and read the indicated value.

A Measurement (10 A range)

! CAUTION

Note that the product may be damaged if current exceeding the selected measurement range is applied for a long time (for the 10 A range, continuous current must be limited to 7A, or to less than one minute if over 7A)

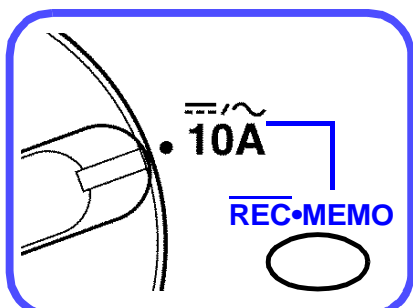

1. Move the function selector to the **10A** position.
2. Select **DC** (—) or **AC** (～) using the **REC•MEMO** button.

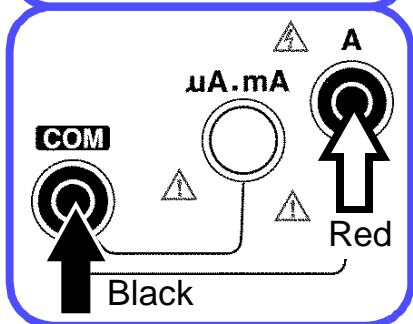

3. Connect the red test lead to terminal **A**, and the black test lead to terminal **COM**.
4. Connect the test leads to the measurement object, and read the indicated value.
The Auto Range function is not provided.

2.4 Resistance Measurement



! DANGER

- Never apply voltage to test leads when the Resistance function is selected. Doing so may damage the product and result in personal injury.
- To avoid electrical accidents, remove power from the circuit before measuring.

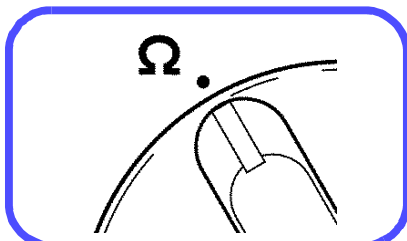

1. Move the function selector to the Ω position.

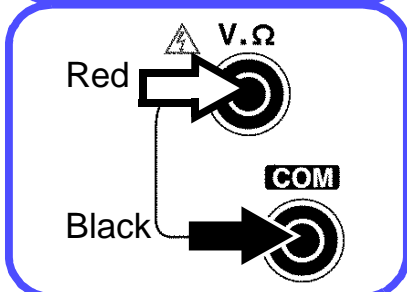

2. Connect the red test lead to terminal **V.Ω**, and the black test lead to terminal **COM**.

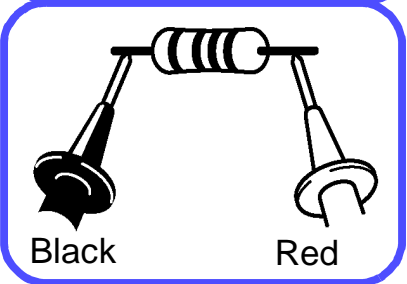

3. Connect the test leads to the measurement object, and read the indicated value.

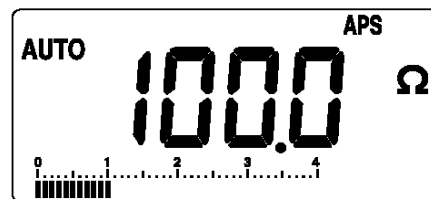

Selecting the manual range: **RANGE** (AUTO is turned off)
 Reselecting the auto range: **RANGE** (Press for at least 1 second) ("AUTO" lights up)

Holding the measured value:
 ❖ HOLD AUTO Function, page 25) or
 ❖ HOLD Function, page 26)

H.AUTO/REL → Measurement → Intermittent sound → Move the test leads away from the measurement object.
H.AUTO/REL + Power-on → Measurement → **H.AUTO/REL**

2.5 Continuity Check



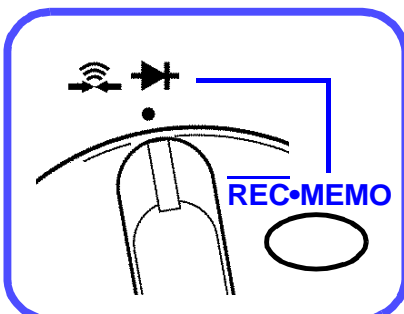

⚠ DANGER

- Never apply voltage to test leads when the Continuity function is selected. Doing so may damage the product and result in personal injury.
- To avoid electrical accidents, remove power from the circuit before measuring.



1. Move the function selector to the  position.

2. Select Diode () using the **REC·MEMO** button ( lights up).

3. Connect the red test lead to terminal **V.Ω**, and the black test lead to terminal **COM**.

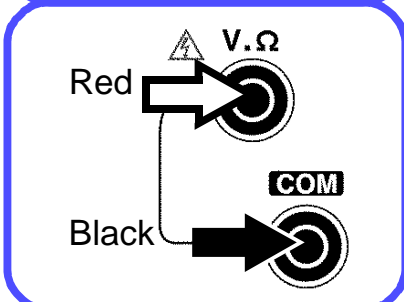

4. Connect the test leads to the measurement object.

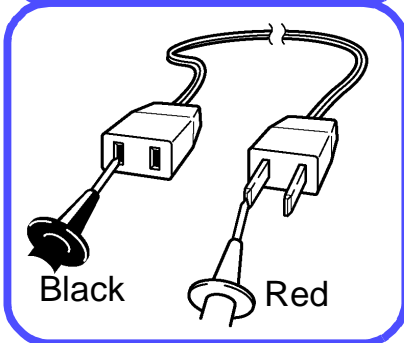

When the continuity (threshold: $50 \pm 30 \Omega$ or less) is established, the beeping sounds and the resistance is displayed (fixed to the 420- Ω range).

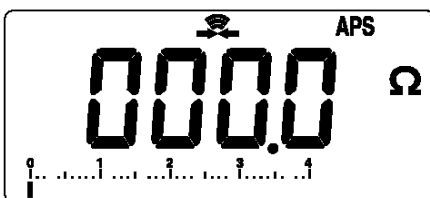





2.6 Diode Check

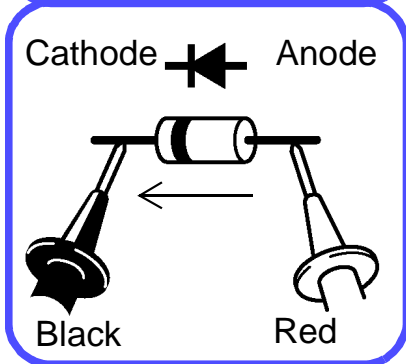
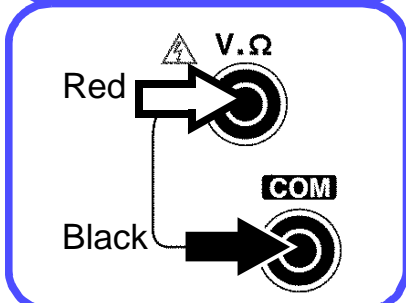
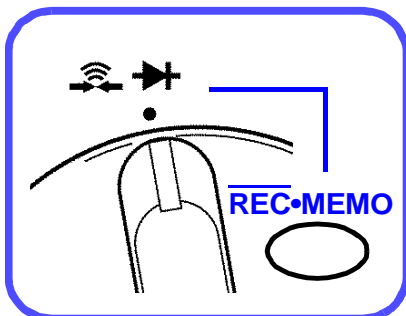

! DANGER

- Never apply voltage to test leads when the Diode Check function is selected. Doing so may damage the product and result in personal injury.
- To avoid electrical accidents, remove power from the circuit before measuring.



1. Move the function selector to the  position.
2. Select Diode () using the **REC·MEMO** button ( lights up).
3. Connect the red test lead to terminal **V.Ω**, and the black test lead to terminal **COM**.
4. Connect the test leads to the measurement object.

The display shows forward voltage (0.4 V to 0.7 V) for a normal diode.

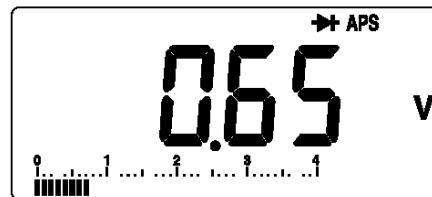

Appearance of O.F:

The diode is invertedly connected or broken.

Appearance at approximately 0 V:

The diode is short-circuited.

Additional Functions

Chapter 3

3.1 HOLD AUTO Function

Functions	$\sim V/\Omega/40\mu A/\mu A/mA/10A$
Description	Simply moving the test leads away from the measurement object holds the measured value. This function is useful when it is difficult to read the displayed value in the current location or both hands are being used to conduct the measurement.

H.AUTO/REL

HOLD
(blinks)
Measure

HOLD
(lights up)
Beeping sound

HOLD
(blinks)

The measured value is held.

1. Select the desired function and connect the the measurement product.
2. Press the **H.AUTO/REL** button. ("HOLD" blinks) (In the measurement of resistance played.)
3. Connect the test leads to the measurement the measured value is stabilized, an intermittent sound is generated. ("HOLD" lights up)
4. When the intermittent sound is heard, move the test leads away from the measurement object. The measured value immediately before the test leads are removed is held. ("HOLD" blinks)

Blind zone	$\sim V/\Omega/40\mu A/\mu A/mA/10A$: 420 mV range, less than 400 counts (other range)
	$\sim A/\Omega/40\mu A/\mu A/mA/10A$: less than 40 counts
	Ω : O.F

NOTE HOLD AUTO is disabled in the AC/DC 420-mV range.



Canceling the hold mode: Press **H.AUTO/REL** again. (HOLD is turned off)

Saving the data: Press **REC•MEMO**

3.2 HOLD Function

Functions	$\sim V / \text{Hz} / \Omega / \mu A / \text{mA} / 10A$
Description	This function holds the currently measured value.

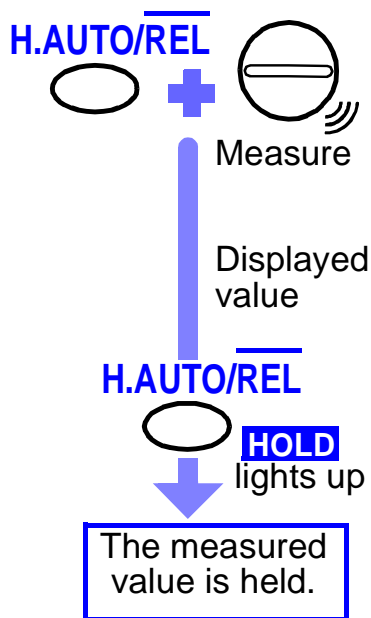

1. Turn on the power while pressing the **H.AUTO/REL** button, and hold the button down until a beeping sound is generated (toggle the function selector to the desired position).
2. Press the **H.AUTO/REL** button again at the measured value to be held. The value is held. ("HOLD" lights up)
3. To cancel the hold mode, press the **H.AUTO/REL** button again.

NOTE The Hold function is active until the measurement product is turned off.

3.3 Overflow Warning Function

Functions	$\sim V$ / $\text{---} V$ / $40\mu A$ / μA / mA / $10A$
Description	When the measured value exceeds the maximum indication (4200 counts), O.F is displayed and an intermittent sound is generated.

When the measured value exceeds 1050 counts in the ranges specified below, O.F is displayed and an intermittent sound is generated.

- Maximum range (1000-V range) of DC voltage measurement ($\text{---} V$) or AC voltage measurement ($\sim V$)
- 10-A range of current measurement

Example: When the measured value exceeds 1050 counts in the 1000-V range of AC voltage measurement ($\sim V$)

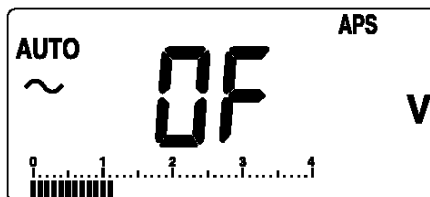

3.4 Relative Display Function

Functions	$\sim V / \Omega / 40 \mu A / \mu A / mA / 10A$
Description	Once an arbitrary value is specified as a reference, the relative value against the reference is displayed. This function is useful to check any discrepancy from the reference.

Checking any discrepancy from the reference (when 10 V is defined as the reference in the voltage measurement)

Measure a voltage of 10 V

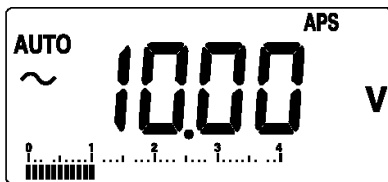

H.AUTO/REL

The manual range is enabled.  for at least 1 second

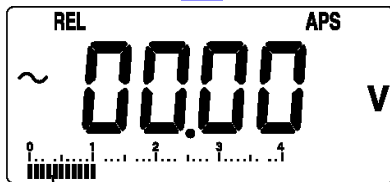

The bar graph indicates the measured value.



Any discrepancy from the reference (10 V) is displayed. In the case of a negative value, "-" is also displayed.

NOTE

The measurement range is fixed to the range that is active when the H.AUTO/REL button is pressed. If the reference value deviates from the full scale, O.F is displayed. While O.F is displayed, the Relative function is disabled.

1. Move the function selector to the desired position and connect the test leads to the measurement product. (example: $\sim V$)
2. Connect the test leads to the measurement object.
3. Press the **H.AUTO/REL** button for at least 1 second for the value to be defined as the reference. (Example: Press the button at 10 V. "REL" lights up and "0000" is displayed.)
4. Measure the voltage again and read the displayed value (discrepancy from the reference).

(The measured value minus the reference is displayed.)

Application: Using the Relative Display function for the purpose of zero adjustment in the measurement of low resistances

Short-circuit the test leads

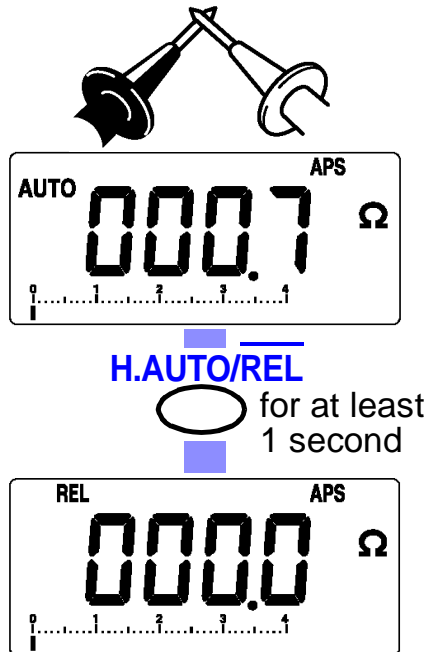

Measure the resistance.

1. Move the function selector to the Ω position and connect the test leads to the equipment.
2. Short-circuit the test leads. The resistance of the test leads is displayed.
3. Press the **H.AUTO/REL** button for at least 1 second. ("REL" lights up, "0000")
4. Connect the test leads to the measurement object, and read the indicated value.



Canceling the Relative function:

Press **H.AUTO/REL**

3.5 Auto Power Save Function

Functions	All functions
Description	Approximately 10 minutes after completing final operation, the measurement product automatically enters Power Save mode. When the measurement product is turned on, it automatically enters Auto Power Save mode ("APS" lights up).

NOTE

- In Power Save mode, the LCD is blank but power is supplied to the measurement product.
- To avoid battery depletion, turn the function selector OFF after use (the Auto Power Save feature consumes a small amount of current).

Recovery from Power Save mode:

Turn off the function selector. In the current measurement, disconnect the test leads from the terminals and turn off the function selector.

NOTE

After the measurement product exits Power Save mode, all conditions are reset. If the measurement product is to be used for an extended period, Auto Power Save mode should be canceled in advance.

Canceling the Auto Power Save function:



Turn on the measurement product while pressing the **REC•MEMO** button. (Hold down the button until the beeping sound is generated.)

The Auto Power Save function is disabled until the measurement product is turned off (APS is turned off).

3.6 Voltage Detecting Function

! CAUTION

This function should be used for the covered power line. Depending on the measurement status, the power may not be detected. Before using this function, check that the measuring device can detect the existing live power line.

Functions	$\sim V$
Description	This function allows you to check whether the power line is live. If the line is live, the measurement product indicates that fact both audibly (intermittent sound) and visually (display).

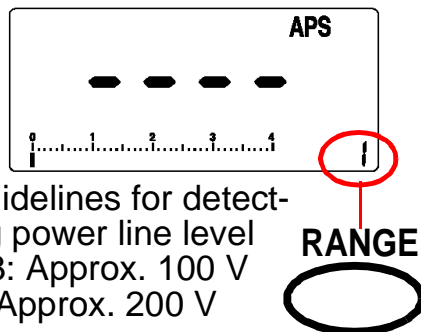
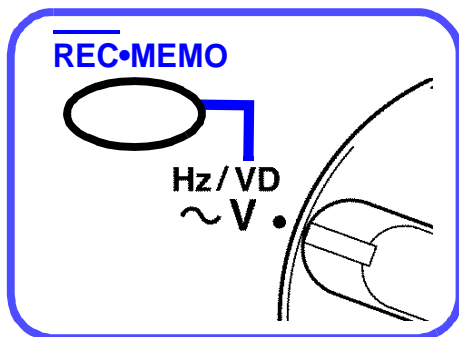

Guidelines for detecting power line level
 1-3: Approx. 100 V
 4: Approx. 200 V

1. Move the function selector to the $\sim V$ position, and press the **REC·MEMO** button twice ("1" lights up).
2. Bring the measurement product close to the power line.
3. If necessary, change the detection range with the **RANGE** button.

When the line is live, the bar graph fluctuates. When the voltage is outside of the detection range, an intermittent sound is generated and the display blinks.

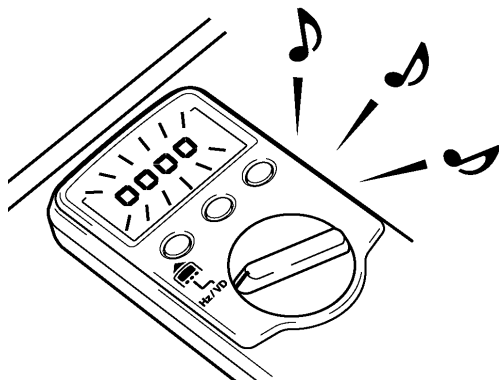

The voltage detecting sensor is mounted at the top of the measurement product. Bring the top close to the power line, as shown at left.

3.7 Dynamic Recording Function

Functions $\sim V/\Omega/40\mu A/\mu A/mA/10A$

Description This function allows the maximum (MAX), minimum (MIN), average (AVG), and currently measured values to be displayed selectively. It is useful for measuring any discrepancy over an extended period.

REC·MEMO
Press for at least 1 second.

Current value
~ 100.4 V

Maximum value
~ 150.5 V

Minimum value
~ 069.5 V

Average value
~ 106.2 V

H.AUTO/REL

1. Select the desired function and connect the test leads to the measurement product.
2. Connect the test leads to the measurement object.
3. Press the **REC·MEMO** button for at least 1 second. ("MAX MIN AVG" lights up)
4. Select the item using the **H.AUTO/REL** button.

- The maximum, minimum, and average measured after the activation of the Recording function are automatically recorded (recording interval: approx. 0.4 seconds).
- When the maximum and/or minimum is updated, a beeping sound is generated.
- The simple average is displayed within 30 min from the start of measurement and the moving average is displayed after the elapse of 30 min.
- While the Recording function is in operation, the Auto Power Save function is disabled (APS is turned off). The range is fixed.



Appearance of O.F: The measurement range exceeds the specified level.

Before using the Recording function, use the manual range to set the range assumed as the maximum level.

Canceling

Press **REC·MEMO** again.

3.8 Memory Function

Saving data to memory

Functions	$\sim V/\Omega/40\mu A/\mu A/mA/10A$
Description	This function memorizes the measured value held using the Hold Auto or Hold function.

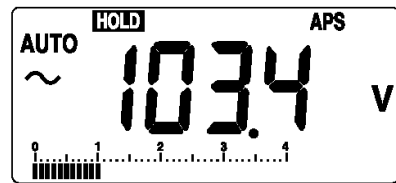

1. Hold the measured value using the Hold Auto or Hold function.
2. Press the **REC·MEMO** button in hold mode. The value displayed is saved in memory of the number specified.

Wait a moment for current value display on the LCD.
Up to 20 values can be saved.

Memory numbers cannot be specified.
The data is saved to the memory in order, starting from 01. When the memory number reaches 20, the subsequent data sets are overwritten to memory starting from number 01.

Calling data from memory

Call data from memory as specified below.



1. Turn on the power while pressing the **RANGE** button. Move the function selector to the \sim V position (hold the button down until a beeping sound is generated).
2. Press the **RANGE** button to select the memory number. The saved data is displayed on the LCD.

Deleting all data from memory

Delete all data from memory as specified below.



Press both buttons simultaneously for at least 1 second.

In Memory Call mode, press the **REC•MEMO** and **RANGE** buttons simultaneously for at least 1 second. All data is deleted from memory.

NOTE Data in the memory of the specified number cannot be deleted.



Returning to the normal measurement mode: Toggle the function selector. (Five minutes after completing final operation, the measurement product returns to the normal measurement mode.)

Specifications

Chapter 4

4.1 General Specifications

Measurement Method	Dual integration
AC Measurement System	Average rectifying measurement
Function	DC voltage ($\text{---} V$), AC voltage ($\sim V$), Resistance (Ω), DC current ($\text{---} A$), AC current ($\sim A$), Continuity check ($\text{---} \text{---}$), Diode check ($\text{---} \text{---}$), Frequency (Hz), Voltage detecting
Additional Function	Auto Range function Manual Range function Hold function Hold Auto function Relative Display Function Dynamic Recording function Memory function (Registration, call, deletion) Auto Power Save function Overflow Warning function Battery-Life Warning function
Display Type	TN type LCD, 1/4 duty, dynamic drive
Display Elements	3(1/2) dgt. Max. 4200 counts (19,999 counts for Hz function) Number display: "20" Polarity indicator: "-" sign (automatic) Overflow indicator: "OF" or "-OF"
Units and Symbols	AUTO/REL/HOLD/MAX/MIN/AVG/ $\text{---} \text{---}$ / $\text{---} \text{---}$ / APS M/k/m/ μ /Hz/ Ω /A/V/ B / \sim / --- /MEM
Bar-graph Indicator	Indication of scale, 42-dot bar graph, and \pm (polarity)

Input Terminals	V.Ω terminal (V, Hz, Ω, continuity, diode) μA.mA/ A/ COM terminals Equipped with terminal shutter to prevent improper operation.
Function Selector	Rotary selector
Range Switching	Auto/Manual Range
Sampling Rate	2.5 S/s (except Frequency), 5 S/s (Frequency), 25 S/s (Update of bar graph)
Power Supply	Two manganese (R03) batteries or two alkaline (LR03) batteries Rated supply voltage: 1.5VDC × 2
Battery-Life Warning	B indicates low battery (2.2 V±0.1V or less)
Continuous Operating Time	Approx. 100 hours (= V, with R03 manganese batteries) Approx. 200 hours (= V, with LR03 alkaline batteries)
Maximum Rated Voltage to Earth	1000VDC/ 1000Vrms(sin), or 10 ⁷ V•Hz(CATII) 600VDC/ 600Vrms(sin), or 10 ⁷ V•Hz(CATIII)
Maximum Input Voltage	~ V/ = V/Ω/Hz 1000VDC/ 1000Vrms(sin), or 10 ⁷ V•Hz(CATII) 600VDC/ 600Vrms(sin), or 10 ⁷ V•Hz(CATIII)
Maximum Input Current	~ A/ = A 42μA - 420mA range: 420 mA DC/AC (fuse 0.5A/700V DC/AC) 10A range:10 A DC/AC (fuse 10A/600V DC/AC)
Dielectric Strength	Input terminals to case: 7.4 kVrms sin (50/60 Hz for one minute)
Noise Suppression	NMRR: = V -60dB or better (50/60 Hz) CMRR: = V -100dB or better (50/60 Hz) ~ V -60dB or better (50/60 Hz)
Maximum Rated Power	20 mVA (supply voltage 3.0 V) 0.1 mVA (Auto Power Saving, supply voltage 3.0 V)

Operating Environment	Indoors, altitude up to 2000 m (6562-ft.)
Operating Temperature & Humidity	0 to 50°C (32 to 122°F), at 80%RH or less (non-condensating)
Storage Temperature & Humidity	-20 to 60°C (-4 to 140°F), at 70%RH or less (non-condensating)
Temperature Characteristic	(Measurement accuracy) $\times 0.1/^{\circ}\text{C}$ (except $23\pm 5^{\circ}\text{C}$)
Size & Weight	Approx. $76\text{W} \times 167\text{H} \times 33\text{D}$ mm ($2.99\text{W} \times 6.57\text{H} \times 1.30\text{D}$) (without protrusions) Approx. 260 g (9.2 oz)
Accessories	9207-10 TEST LEAD Instruction Manual Two R03 manganese batteries Protective holster(3256-51) or 9378 CARRYING CASE (3256-50)
Applicable Standards	Safety EN61010-1:2001 EN61010-031:2002 Pollution Degree 2 Measurement Category III(600 V), Measurement CategoryII(1000 V) (Anticipated Transient Overvoltage: 6000 V) EMC EN61326:1997+A1:1998+A2:2001 +A3:2003
Options	9207-10 TEST LEAD 9014 HIGH VOLTAGE PROBE*(30 kVDC) (*no CE marking) 3853 CARRYING CASE (for 3256-51 can be packaged together with the holster.) 9378 CARRYING CASE (Standard item for the 3256-50)

Protective Fuse	10A terminal: TDC600-10A (made by Cooper Bussmann*) Rating 10 A/600 VAC Fast-Acting Breaking capacity: 10 kA/250 VAC, 200 A/600 VAC μAmA terminal:70125 (made by SIBA Inc.) Rating 0.5 A/700 VAC Fast-Acting Breaking capacity: 50 kA *Cooper Industries Inc., Bussmann Division, USA
-----------------	--

4.2 Accuracy



Accuracy guarantee for 23±5°C(73±9°F), 80%RH or less temperature and humidity

Guaranteed accuracy period 1 year

Regulated power supply range 3.4 V or lower (until the **B** mark lights up)

(rdg.: displayed value, dgt.: resolution)

Voltage Measurement

	Range [V]	Accuracy ±(rdg.)±(dgt.)	Input Impedance (Frequency range)
	420.0 m	±0.5%±2	100 MΩ or more
	4.200	±0.5%±2	Approx. 11MΩ
	42.00	±0.5%±2	Approx. 10MΩ
	420.0	±0.5%±2	Approx. 10MΩ
	1000	±0.5%±2	Approx. 10MΩ
 *1	420.0 m	±1.5%±3*2	100MΩ or more (50 to 100 Hz)
	4.200	±1.2%±3	Approx. 11MΩ (50 to 500 Hz)
	42.00	±1.2%±3	Approx. 10MΩ (50 to 500 Hz)
	420.0	±1.2%±3	Approx. 10MΩ (50 to 500 Hz)
	1000	±1.2%±6	Approx. 10MΩ (50 to 500 Hz)

Overload protection (for one minute):
 1000 VDC, 1000 Vrms(sin)(CAT II),
 600 VDC, 600 Vrms(sin)(CATIII), or 10⁷V•Hz

*1: For the input of less than 10% of the full scale, ±2 dgt. is added to the above measurement accuracies.



*2: The above measurement accuracy for the 420.0 mV range is not defined for inputs of less than 1.0 mV.

(rdg.: displayed value, dgt.: resolution)

Frequency Measurement

	Range [Hz]	Accuracy $\pm(\text{rdg.})\pm(\text{dgt.})$	Input level (Range)
Hz *1	199.99	$\pm 0.02\% \pm 2$	1: 0.8 to 4 V (4.200V)
	1999.9	$\pm 0.02\% \pm 1$	2: 4 to 40 V (42.00V)
	19.999k	$\pm 0.02\% \pm 1$	3: 40 to 400 V (420.0V)
	199.99k	$\pm 0.02\% \pm 1$	4: 400 to 1000 V (1000V)
	500.0k	$\pm 0.02\% \pm 1$	
Overload protection (for one minute): 1000 VDC, 1000 Vrms(sin)(CAT II), 600 VDC, 600 Vrms(sin)(CATIII), or $10^7 \text{V}\cdot\text{Hz}$			
*1: Frequencies of less than 0.50 Hz cannot be measured. Maximum input voltage: 1000 Vrms(sin) or $10^7 \text{V}\cdot\text{Hz}$			

Resistance Measurement/ Continuity Check/ Diode Check

	Range	Accuracy $\pm(\text{rdg.})\pm(\text{dgt.})$	Open terminal voltage	Measurement current (max.) (Reference value)
Ω (Resistance)	420.0 Ω	$\pm 0.7\% \pm 4$	3.4 V or less	700 μA
	4.200k Ω	$\pm 0.7\% \pm 2$	Approx. 0.7V	250 μA
	42.00k Ω	$\pm 0.7\% \pm 2$	Approx. 0.5V	50 μA
	420.0k Ω	$\pm 0.7\% \pm 2$	Approx. 0.5V	5 μA
	4.200M Ω	$\pm 1.5\% \pm 2$	Approx. 0.5V	0.5 μA
	42.00M Ω	$\pm 2.5\% \pm 2$	Approx. 0.5V	0.05 μA
 (Continuity)	420.0 Ω	$\pm 0.7\% \pm 4$	3.4 V or less	Threshold: 50 $\Omega \pm 30\Omega$
 (Diode)	2.00V*1	$\pm 5.0\% \pm 2$	3.4 V or less	700 μA
Overload protection (for one minute): 1000 VDC, 1000 Vrms(sin)(CAT II), 600 VDC, 600 Vrms(sin)(CATIII), or $10^7 \text{V}\cdot\text{Hz}$				
*1: The measurement range varies depending on the battery voltage level.(2.10 V to 2.90 V)				
*2: A beeping sound is generated when the continuity is established.				

(rdg.: displayed value, dgt.: resolution)

Current Measurement

	Range [A]	Accuracy $\pm(\text{rdg.})\pm(\text{dgt.})$	Input Impedance (Shunt resistance)
$\text{---} \mathbf{A}$	42.00 μ	$\pm 1.5\% \pm 4$	Approx. 10k Ω
	420.0 μ	$\pm 1.5\% \pm 4$	Approx. 100 Ω
	4200 μ	$\pm 1.5\% \pm 4$	Approx. 100 Ω
	42.00m	$\pm 1.5\% \pm 4$	Approx. 1 Ω
	420.0m	$\pm 1.5\% \pm 4$	Approx. 1 Ω
	10.00*2	$\pm 1.5\% \pm 4$	Approx. 0.01 Ω
	$\sim \mathbf{A}$ *1	42.00 μ	$\pm 2.5\% \pm 5$
420.0 μ		$\pm 2.5\% \pm 5$	Approx. 100 Ω
4200 μ		$\pm 2.5\% \pm 5$	Approx. 100 Ω
42.00m		$\pm 2.5\% \pm 5$	Approx. 1 Ω
420.0m		$\pm 2.5\% \pm 5$	Approx. 1 Ω
10.00*2		$\pm 2.5\% \pm 5$	Approx. 0.01 Ω
Protective Fuse 42 μ A to 420mA range: 0.5 A/700 VAC, Breaking capacity 50 kA 10A range: 10A/600VAC, Breaking capacity 10 kA/250 VAC, 200 A/600 VAC *1: For the input of less than 10% of the full scale, ± 2 dgt is added to the above measurement accuracies. *2: For the 10-A range, the measurement time is infinite at or below 7 A and within 1 minute for 7 A to 10 A.			

Maintenance and Service

Chapter 5

5.1 Replacing the Batteries and Fuses



! DANGER

- To avoid electric shock when replacing the batteries and fuses, first disconnect the test leads from the object to be measured.
- Before using the product after replacing the batteries or fuses, replace the cover and screw.
- Do not mix old and new batteries, or different types of batteries. Also, be careful to observe battery polarity during installation. Otherwise, poor performance or damage from battery leakage could result.
- To avoid the possibility of explosion, do not short circuit, disassemble or incinerate batteries.
- Handle and dispose of batteries in accordance with local regulations.
- Replace the fuse only with one of the specified characteristics and voltage and current ratings. Using a non-specified fuse or shorting the fuse holder may cause a life-threatening hazard.

5.1 Replacing the Batteries and Fuses

A fuse is mounted to the $\mu\text{A.mA}$ and **A** terminals in order to protect the circuit. If the current cannot be measured, the fuse may have blown due to overcurrent. Replace the fuse or battery in accordance with the procedure specified below.

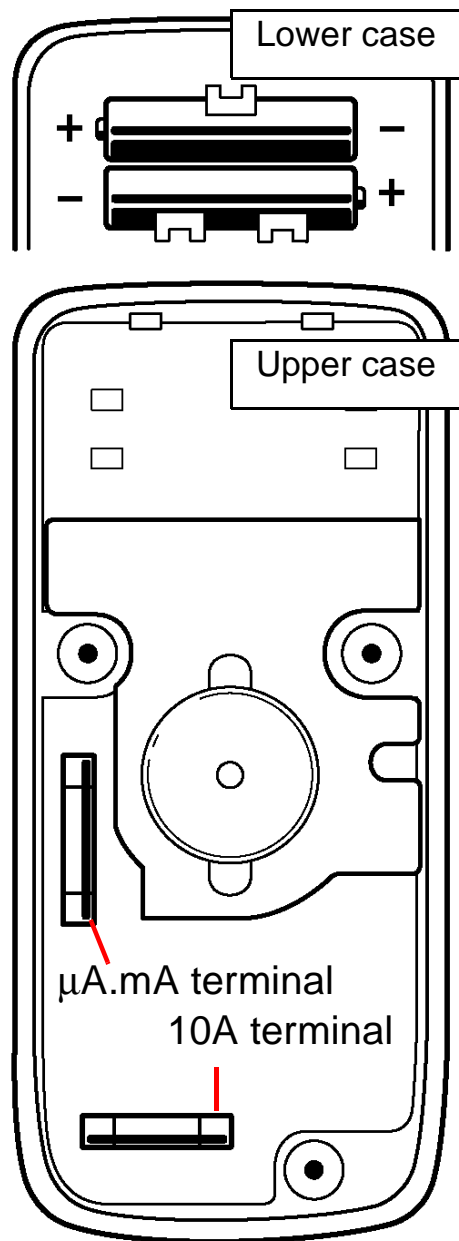

Necessary tool: Phillips screwdriver

1. Disconnect the test leads from the measurement circuit, and make sure the function selector is in the OFF position.
2. Position the measurement product with the rear case (bottom face) pointing upward, and use the Phillips screwdriver to remove the three lock bolts.
3. Lift and remove the rear case.
4. Replace the two manganese batteries (R03) mounted to the rear case, or the fuse mounted to the front case.
5. Mount the rear case and tighten the three lock bolts.

Fuse type

10A terminal:

TDC600-10A (made by Cooper Bussmann*), Fast-Acting, Rating 10A/600VAC, Breaking capacity 10 kA/250 VAC, 200 A/600 VAC

μAmA terminal:

70125 (made by SIBA Inc.), Fast-Acting, Rating 0.5 A/700 VAC, Breaking capacity 50 kA

*Cooper Industries Inc., Bussmann Division, USA

NOTE

Different fuses are mounted to the μA , mA and A terminals. When replacing a fuse, make sure you are accessing the correct terminal.

5.2 Cleaning

To clean the product, wipe it gently with a soft cloth moistened with water or mild detergent. Never use solvents such as benzene, alcohol, acetone, ether, ketones, thinners or gasoline, as they can deform and discolor the case.

5.3 Service

- If the product seems to be malfunctioning, confirm that the batteries are not discharged, and that the test leads and fuse are not open circuited before contacting your dealer or Hioki representative.
- To avoid corrosion from battery leakage, remove the batteries from the product if it is to be stored for a long time.

HIOKI

DECLARATION OF CONFORMITY

Manufacturer's Name: HIOKI E.E. CORPORATION
Manufacturer's Address: 81 Koizumi, Ueda, Nagano 386-1192, Japan
Product Name: DIGITAL HiTESTER
Model Number: 3256-50
Accessory: 9207-10 TEST LEAD

The above mentioned products conform to the following product specifications:

Safety: EN61010-1:2001
EN61010-031:2002
EMC: EN61326:1997+A1:1998+A2:2001+A3:2003
Class B equipment
Portable test, measuring and monitoring
equipment used in low-voltage distribution
systems

Supplementary Information:

The products herewith comply with the requirements of the Low Voltage Directive 73/23/EEC and the EMC Directive 89/336/EEC.

HIOKI E.E. CORPORATION

15 September 2006

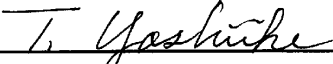

Tatsuyoshi Yoshiike
President

3256C999-04

HIOKI

HIOKI E. E. CORPORATION

INSPECTION CERTIFICATE

HIOKI E.E. CORPORATION hereby certifies that the under-mentioned product(s) has been tested and inspected in accordance with applicable HIOKI calibration procedures, and proven to meet or exceed published measurement specifications. We also certify that the measurement standards and instruments used in the calibration procedure are traceable to the national standards organization.

Model: 3256-50

S/N: _____

INSPECTOR

T. Kito

T. Kito

HIOKI 3256-50/51 DIGITAL HiTESTER
Instruction Manual

Publication date: September 2006 Revised edition 4

Edited and published by HIOKI E.E. CORPORATION
Technical Support Section

All inquiries to International Sales and Marketing Department

81 Koizumi, Ueda, Nagano, 386-1192, Japan

TEL: +81-268-28-0562 / FAX: +81-268-28-0568

E-mail: os-com@hioki.co.jp

URL <http://www.hioki.co.jp/>

Printed in Japan 3256C981-04

-
-
- All reasonable care has been taken in the production of this manual, but if you find any points which are unclear or in error, please contact your supplier or the International Sales and Marketing Department at HIOKI headquarters.
 - In the interests of product development, the contents of this manual are subject to revision without prior notice.
 - Unauthorized reproduction or copying of this manual is prohibited.
-
-

HIOKI

HIOKI E. E. CORPORATION

HEAD OFFICE

81 Koizumi, Ueda, Nagano 386-1192, Japan
TEL +81-268-28-0562 / FAX +81-268-28-0568
E-mail: os-com@hioki.co.jp
URL <http://www.hioki.co.jp/>

HIOKI USA CORPORATION

6 Corporate Drive, Cranbury, NJ 08512, USA
TEL +1-609-409-9109 / FAX +1-609-409-9108

3256C981-04 06-09H



Printed on recycled paper
