

Differential pressure transmitter

testo 6321

Measurement of differential pressure in the measuring range from 100 Pa to 2 bar

Magnet valve for the automatic zero-point adjustment guarantees high temperature-independent accuracy and long-term stability

Adjustment and analysis via parameterization and adjustment software save time and costs in commissioning and maintenance

Available with and without display



hPa

A differential pressure transmitter with a good price/performance ratio for applications in air conditioning and ventilation technology.

The testo 6321 is excellently suitable for the differential pressure-based monitoring of air filters, blowers and air flow, for a good climate with optimum energy efficiency.

The highly accurate and long-term stable testo 6321 provides the measurement values needed to monitor and regulate differential pressure safely and efficiently in air conditioning, ventilation and cleanroom technology.

Technical data

Measurement parameters

Differential pressure

Measuring range	0 to 100 Pa 0 to 10 hPa 0 to 20 hPa 0 to 50 hPa 0 to 100 hPa 0 to 500 hPa 0 to 1000 hPa 0 to 2000 hPa	-100 to 100 Pa -10 to 10 hPa -20 to 20 hPa -50 to 50 hPa -100 to 100 hPa -500 to 500 hPa -1000 to 1000 hPa -2000 to 2000 hPa
Measurement uncertainty*	±1.2% of measuring range final value ±0,3 Pa Temperature gain drift: 0.05% of measuring range per Kelvin deviation from nominal temperature 22 °C Zero-point drift: 0% (due to zero-point adjustment)	
Sensor	Piezoresistive sensor	
Autom. zero-point adjustment	via magnetic valve	
Overload capacity	Measuring range	Overload
	0 to 100 Pa	20000 Pa
	0 to 10 hPa	200 hPa
	0 to 20 hPa	200 hPa
	0 to 50 hPa	750 hPa
	0 to 100 hPa	750 hPa
	0 to 500 hPa	2500 hPa
	0 to 1000 hPa	2500 hPa
	0 to 2000 hPa	2500 hPa
	-100 to 100 Pa	20000 Pa
	-10 to 10 hPa	200 hPa
	-20 to 20 hPa	200 hPa
	-50 to 50 hPa	750 hPa
	-100 to 100 hPa	750 hPa
	-500 to 500 hPa	2500 hPa
	-1000 to 1000 hPa	2500 hPa
	-2000 to 2000 hPa	2500 hPa

Inputs and outputs

Analog outputs

Output type	0 to 1/5/10 V (4-wire) 4 to 20 mA (4-wire)
Measuring rate	1/s
Resolution	12 bit
Accuracy of the analog outputs	0 to 1 V ±2.5 mV 0 to 5 V ±12.5 mV 0 to 10 V ±25 mV 4 to 20 mA ±0.05 mA
Max. load	500 Ω

Further outputs

other analog outputs	Mini DIN for P2A software (adjustment and parameterization software)
----------------------	--

Supply

Voltage supply	20 to 30 V AC/DC
Current consumption	300 mA

General

Housing

Material / colour	ABS / white (RAL 9010) or light grey
-------------------	--------------------------------------

Weight	Approx. 160 g
--------	---------------

Display

Display	2-line LCD (optional)
---------	-----------------------

Resolution	Measuring range	Resolution
	0 to 100 Pa	0.1 Pa
	0 to 10 hPa	0.01 hPa
	0 to 20 hPa	0.01 hPa
	0 to 50 hPa	0.01 hPa
	0 to 100 hPa	0.1 hPa
	0 to 500 hPa	0.1 hPa
	0 to 1000hPa	1 hPa
	0 to 2000hPa	1 hPa
	-100 to 100 Pa	0.1 Pa
	-10 to 10 hPa	0.01 hPa
	-20 to 20 hPa	0.01 hPa
	-50 to 50 hPa	0.01 hPa
	-100 to 100 hPa	0.1 hPa
	-500 to 500 hPa	0.1 hPa
	-1000 to 1000 hPa	1 hPa
	-2000 to 2000 hPa	1 hPa

Miscellaneous

Protection class	IP65 only when the transmitter is wired and/or sealing plugs are in use
EMC	EC guideline: 2004/108/EC
Automatic zero-point adjustment	Every 60 seconds ex-works

Operating conditions

Temperature of medium	-5 to +50 °C
Humidity of medium	0 ... 90 %RH
Operating temperature	-5 to +50 °C
Storage temperature	-20 to +60 °C

The determination of measurement uncertainty takes place according to GUM (Guide to the Expression of Uncertainty in Measurement):

For the determination of measurement uncertainty, the accuracy of the measuring instrument (hysteresis, linearity, reproduceability), the uncertainty contribution of the test site as well as the uncertainty of the adjustment site (works calibration) are taken into account. For this purpose, the value of $k=2$ of the extension factor, which is usual in measurement technology is used as a basis, which corresponds to a trust level of 95%.

Technical drawings / Connection plan

Technical drawings

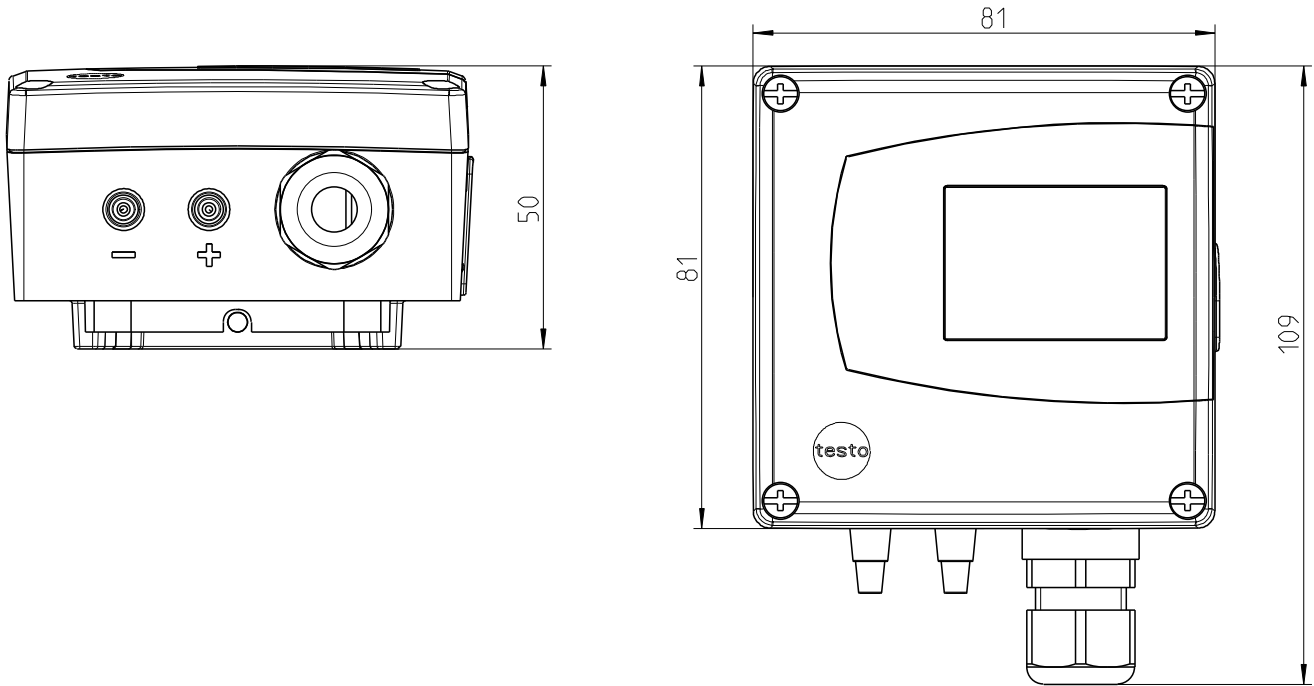

Connection plan

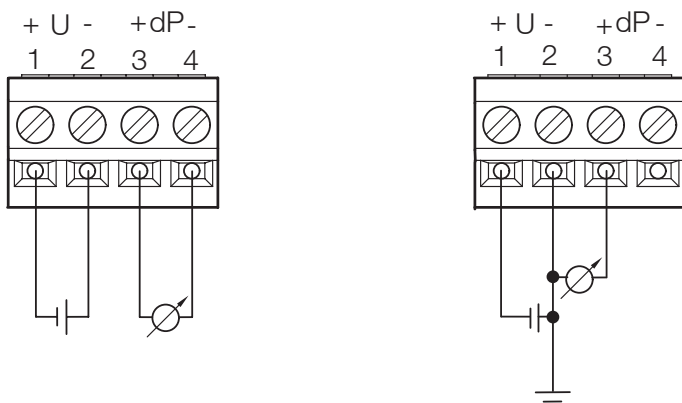

Options / Ordering example

The following options can be specified for the testo 6321

AXX Measuring range
 BXX Analog output/supply
 CXX Display
 EXX Housing colour
 FXX Unit

Delivery incl. wall holder

AXX Measuring range

A03 0 to 100 Pa
 A05 0 to 10 hPa
 A06 0 to 20 hPa
 A07 0 to 50 hPa
 A08 0 to 100 hPa
 A09 0 to 500 hPa
 A10 0 to 1000 hPa
 A11 0 to 2000 hPa
 A23 -100 to 100 Pa
 A25 -10 to 10 hPa
 A26 -20 to 20 hPa
 A27 -50 to 50 hPa
 A28 -100 to 100 hPa
 A29 -500 to 500 hPa
 A30 -1000 to 1000 hPa
 A31 -2000 to 2000 hPa

BXX Analog output / supply

B02 0 to 1 V (4-wire, 24 VAC/DC)
 B03 0 to 5 V (4-wire, 24 VAC/DC)
 B04 0 to 10 V (4-wire, 24 VAC/DC)
 B06 4 to 20 mA (4-wire, 24 VAC/DC)

CXX Display

C00 without display
 C01 with display

EXX Housing colour

E01 Housing colour light grey, incl. Testo logo (coloured)
 E02 Neutral housing, white, without Testo logo
 E03 Neutral housing, white, incl. Testo logo (black/white)

FXX Unit

F01 Pa / min / max
 F02 hPa / min / max
 F03 kPa / min / max
 F04 mbar / min / max
 F05 bar / min / max
 F06 mm H₂O / min / max
 F07 inch H₂O / min / max
 F08 inch H₂G / min / max
 F09 kg/cm² / min / max
 F10 PSI / min / max

Ordering example

Order code for testo 6321 transmitter with the following options:

- Measuring range 0 to 100 Pa
- Analog output 0 to 5 V
- Without display
- Housing colour light grey
- Unit Pa

0555 6321 A03 B03 C00 E01 F01 0 100