

Professional InfraRed Thermometer User Manual

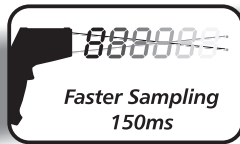

2200°C
3992°F

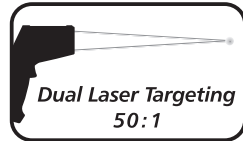

**Please read this manual before switching the unit on.
Important safety information inside.**



InfraRed Thermometer User Manual



Contents

	Page
1.Introduction	4
2.Features.....	4
3.Wide Range Application.....	4
4.Safety.....	5
5.Distance & Spot Size.....	5
6.Specifications.....	6
7.Frontpanel Description.....	7
8.Indicator.....	7
9.Buttons.....	8
10.Functional Design.....	8
11.Data Logger.....	10
11-1.Storing Data.....	10
11-2.Infrared.....	10
11-3.Recalling Data.....	10
11-4.Log Clear Function.....	10
12.Measurement Operation.....	11
13.Battery Replacement.....	11
14.Notes.....	12
15.Maintenance.....	13

1.Introduction

Thank you for purchase of the IR Thermometer. This is capable of non-contact (infrared) temperature measurements at the touch of a button. The built-in laser pointer increases target accuracy while the backlight LCD and handy push-buttons combine for convenient, ergonomic operation.

The Non-contact Infrared Thermometers can be used to measure the temperature of objects' surface that is improper to be measured by traditional (contact) thermometer (such as moving object, the surface with electricity current or the objects which are uneasy to be touched.)

Proper use and care of this meter will provide years of reliable service.

2.Features

- Rapid detection function
- Precise non-contact measurements
- Dual laser sighting
- Unique flat surface, modern housing design
- Automatic Data Hold
- Emissivity Digitally adjustable from 0.10 to 1.0
- MAX MIN AVG DIF temperature displays
- Backlight LCD display
- Automatic selection range and Display Resolution 0.1°C(0.1°F)
- Trigger lock
- Set high and low alarms
- Data logger (LOG)
- Transmit data to pc with USB.

3.Wide Range Application

Food preparation, Safety and Fire inspectors, Plastic molding, Asphalt, Marine and Screen printing, measure ink and Dryer temperature, HVAC/R, Diesel and Fleet maintenance.

4. ⚠ Safety

- Use extreme caution when the laser beam is turned on.
- Do not let the beam enter your eye, another person's eye or the eye of an animal.
- Be careful not to let the beam on a reflective surface strike your eye.
- Do not allow the laser light beam impinge on any gas which can explode.

CAUTION

LASER RADIATION
AVOID DIRECT EYE EXPOSURE



MAXIMUM OUTPUT < 1mW
WAVELENGTH 630-670nm
CLASS 2 LASER PRODUCT

EN 60825-1:1994/A11:1996/A2:2001/A1:2002

5. Distance & Spot Size

As the distance (D) from the object increases, the spot size (S) of the area measured by the unit becomes larger. The relationship between distance and spot size for each unit is listed below. The focal point for each unit is 914mm (36"). The spot sizes indicate 90% encircled energy.

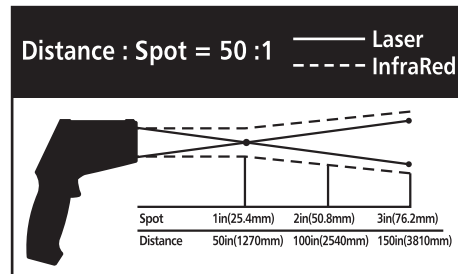

6. Specifications

IR Measurement		
IR Temp. Range	-50 to 2200°C (-58 to 3992°F)	
Optical Resolution	50:1	
Resolution	0.1°C(0.1°F) < 1000; 1°F > 1000	
Accuracy	-50 to 20°C(-58 to 68°F)	±3.0°C(5.4°F)
	20 to 500°C(68 to 932°F)	±1.0% ±1.0°C(1.8°F)
	500 to 1000°C(932 to 1832°F)	±1.5%
	1000 to 2200°C(1832 to 3992°F)	±2.0%
Repeatability	-50 to 20°C(-58 to 68°F)	±1.5°C(2.7°F)
	20 to 1000°C(68 to 1832°F)	±0.5% or ±0.5°C(0.9°F)
	1000 to 2200°C(1832 to 3992°F)	±1.0%

TK Measurement		
TK Temp. Range	-50 to 1370°C(-58 to 2498°F)	
Resolution	0.1°C(0.1°F) < 1000; 1°C(1°F) > 1000	
Accuracy	-50 to 1000°C(-58 to 1832°F)	±1.5% ±3°C(5°F)
	1000 to 1370°C(1832 to 2498°F)	±1.5% ±2°C(3.6°F)
Repeatability	-50 to 1370°C(-58 to 2498°F)	±1.5%

Response Time:	150ms
Spectral Response:	8~14um
Emissivity:	Digitally adjustable from 0.10 to 1.0
Over Range Indication:	LCD will show "----"
Polarity:	Automatic (no indication for positive polarity); Minus (-) sign for negative polarity
Diode Laser:	Output < 1mW, Wavelength 630~670nm, Class 2 laser product
Operating Temp:	0 to 50°C(32 to 122°F)
Storage Temp:	-10 to 60°C (14 to 140°F)
Relative Humidity:	10%~90%RH operating, <80%RH storage
Power Supply:	9V battery, NEDA 1604A or IEC 6LR61, or equivalent
Safety:	"CE" Comply with EMC

Note:

Field of View: Make sure that the target is larger than the unit's spot size. The smaller the target, the closer you should be to it. When accuracy is critical, make sure the target is at least twice as large as the spot size.

7.Front Panel Description

- 1-IR Sensor
- 2-LCD Display
- 3-Type K in
- 4-USB in
- 5-Light/Laser Button
- 6-Up Button
- 7-Down Button
- 8-Mode Button
- 9-Measurement Trigger
- 10-Battery Cover
- 11-Handle Grip

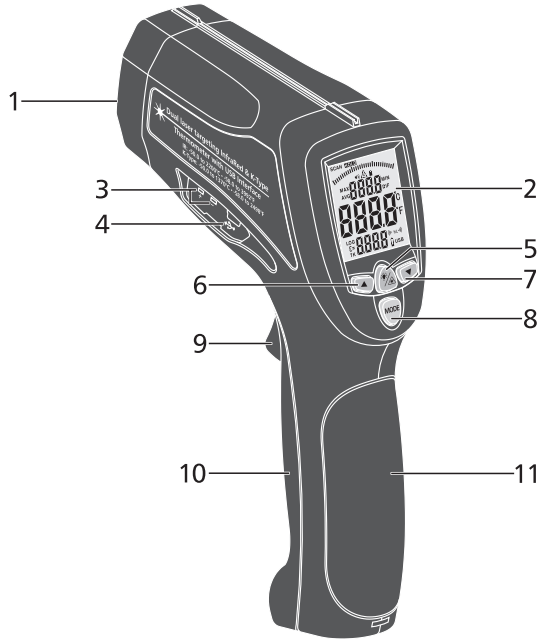

8.Indicator

- 1-Measuring Indication
- 2-Data Hold
- 3-Laser "ON" Symbols
- 4-Lock Symbol
- 5-High Alarm and Low Alarm Symbol
- 6-Max, Min, Avg, Dif Symbol
- 7-Current Temperature Value
- 8-Temperature Values for the Max, Min, Dif, Avg
- 9-Emissivity Symbol
- 10-Type K Symbol
- 11-Emissivity Value and Type K Value
- 12-Low Power Symbols
- 13-°C/°F Symbol
- 14-Data Logger Symbol
- 15-USB Symbol(Transmit Data to PC)

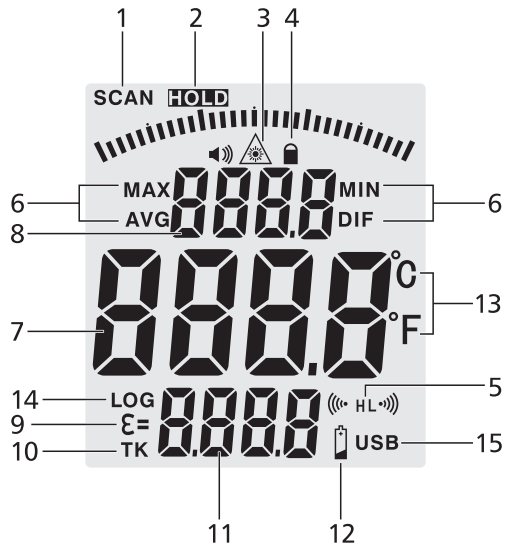

9.Buttons

- 1-Laser/Backlight ON/OFF Button
- 2-Up Button (for EMS,HAL,LAL)
- 3-Down Button (for EMS,HAL,LAL)
- 4-Mode Button
(for cycling through the mode loop)

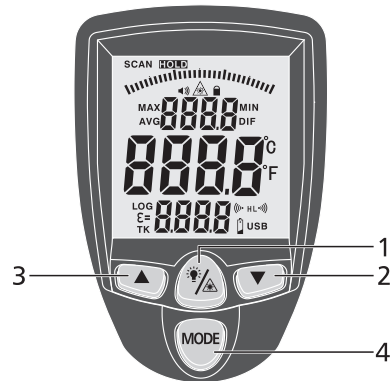

10.Functional Design

- In the measuring time, pressing “MODE” keys to display MAX value, MIN value, DIF value , AVG value, LOG value.
- In the measuring time, if the TYPE-K thermocouple is not connected, you can adjust EMS by pressing “Up/Down” key.
- In the HOLD mode, you can adjust °C/°F by pressing “Up/Down” key.
- You can turn on/off the backlight/laser by pressing “Light/Laser” key at any state.
- To set values for the High Alarm (HAL), Low Alarm (LAL) and Emissivity (EMS), press the “MODE” button until the appropriate code appears in the display, press the “Up/Down” buttons to adjust the desired values.

MODE Button Function

- In the “HOLD” mode, Press the “MODE” button also allows you to access the set state, MAX MIN DIF AVG LOG display.
- Emissivity(EMS), Lock On/Off, HAL On/Off, HAL adjustment, LOW On/Off, LOW adjustment, °C/°F Each time you press set you advance through the mode cycle. The diagram shows the sequence of functions in the mode cycle.

MAX MIN DIF AVG Display

MAX=maximum .Maximum value of measurement.
 MIN=minimum. Minimum value of measurement.
 DIF=difference. Difference value of measurement.
 AVG=average. Average value of measurement.
 Adjustable display by pressing “Up/Down” button.

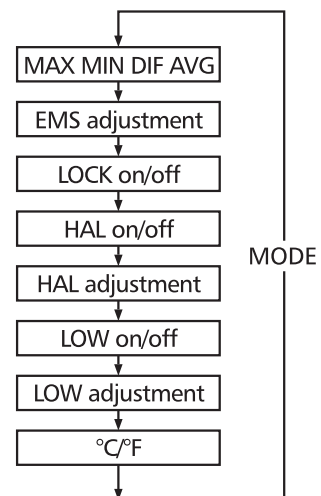

USB Function

- This device affords transmitting the IR and Type K measurement data to the PC via USB.
- Turn on or Shut off USB function:
- Under MAX/MIN/DIF/AVG state, press “**LIGHT/LASER**” button until “**USB**” sign appears in the right lower corner of the LCD. the USB function turn on.
- Then, press the “**LIGHT/LASER**” button again until “**USB**” sign disappears. Thus the USB function shut off.
- Please refer to the help file in software for details.

EMS Adjustment

The Emissivity(EMS) digitally adjustable from 0.10 to 1.0 by pressing “**Up/Down**” button.

LOCK on/off

The lock mode is particularly useful for continuous monitoring of temperatures. Press the “**Up/Down**” button to turn on or off. Press the Measurement Trigger to confirm the lock measurement mode. The IR Thermometer will continuously display the temperature until press again the Measurement Trigger.

HAL on/off

HAL= High alarm

Turn on or off high alarm by pressing “**Up/Down**” button.

HAL adjustment

High alarm value adjust.

Please adjust high alarm value by pressing “**Up/Down**” button

LAL on/off

LAL= Low alarm

Turn on or off low alarm by pressing “**Up/Down**” button.

LAL adjustment

Low alarm value adjust.

Please adjust low alarm value by pressing “**Up/Down**” button

°C/°F

Pressing “**Up/Down**” button to change the temperature unit (°C or °F)

11.Data Logger

11-1.Storing Data

Your thermometer is capable of storing up to 100 data locations.

11-2.Infrared

To store data from an infrared reading, pull the trigger. While holding the trigger, press the “**MODE**” button until LOG appears in the lower left corner of the display; a log location number will be shown. If no temperature has been recorded in the shown LOG location, 4 dashes will appear in the lower right corner. Aim the unit at the target area you want to record, and press the “**Laser/Backlight**” button. The recorded temperature will appear in the lower right corner. To select another log location, press the “**Up**” and “**Down**” keys.

11-3.Recalling Data

To recall stored data after the unit shuts off, press the “**MODE**” button until LOG appears in the lower left corner. A LOG location number will be shown below LOG, and the stored temperature for that location will be display. To move to another LOG location, press the “**Up**” and “**Down**” keys.

11-4.Log Clear Function

The “**Log clear**” function allows you to quickly clear all logged data points. This function can only be used when the unit is in LOG mode. It can be used when the user has any number of LOG locations stored.

You should only use the LOG clear function if you want to clear all the Log location data that is stored in unit’s memory. The “**LOG clear**” function works as follows:

- While in LOG mode, press the trigger, and then press the “**Down**” arrow button until you reach LOG location “0”.

Note: This can only be done when the trigger is pulled. LOG location “0”cannot be accessed, by using the “**Up**” arrow button.

- When LOG location “0” shows in the display, press the “**Laser/Backlight**” button. A tones will sound, and the LOG location will automatically change to “1”, signifying that all data locations have been cleared.

12.Measurement Operation

- 12-1.Hold the meter by its Handle Grip and point it toward the surface to be measured.
- 12-2.Pull and hold the Trigger to turn the meter on and begin testing. The display will light if the battery is good. Replace the battery if the display does not light.
- 12-3.Release the Trigger and the HOLD display icon will appear on the LCD indicating that the reading is being held. In HOLD status, press the "Up" button to turn on or off the laser. And press the "Down" button to turn on or off the backlight.
- 12-4.The meter will automatically power down after approximately 7 seconds after the trigger is released.(Unless the unit is locked on)

Note: Measurement considerations

- Holding the meter by its handle, point the IR Sensor toward the object whose temperature is to be measured. The meter automatically compensates for temperature deviations from ambient temperature. Keep in mind that it will take up to 30 minutes to adjust to wide ambient temperatures are to be measured followed by high temperature measurements, some time (several minutes) is required after the low (and before the high) temperature measurements are made.
- This is a result of the cooling process, which must take place for the IR sensor.

13.Battery Replacement

- 13-1.As battery power is not sufficient, LCD will display "⚡" replacement with one new battery type 9V is required.
- 13-2.Open battery cover, then take out the battery from instrument and replace with a new 9-Volt battery and place the battery cover back.

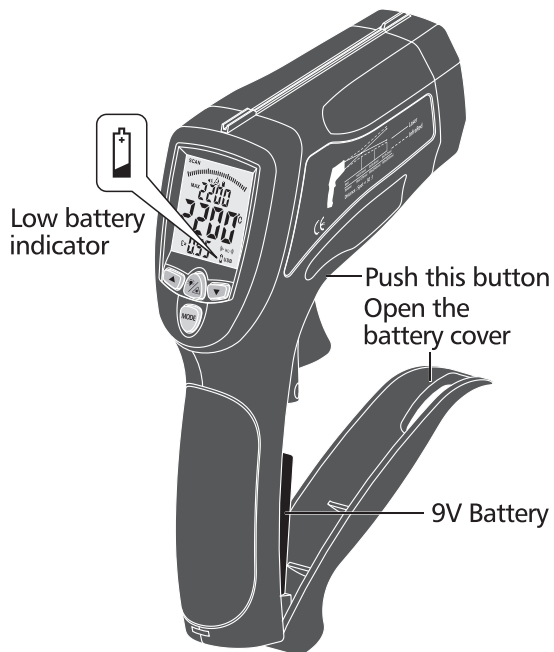

14. Notes

• How it Works

Infrared thermometers measure the surface temperature of an object. The unit's optics sense emitted, reflected, and transmitted energy, which is collected and focused onto a detector. The unit's electronics translate the information into a temperature reading, which is displayed on the unit. In units with a laser, the laser is used for aiming purposes only.

• Field of View

Make sure that the target is larger than the unit's spot size. The smaller the target, the closer you should be to it. When accuracy is critical, make sure the target is at least twice as large as the spot size.

• Distance & Spot Size

As the distance (D) from the object increases, the spot size (S) of the area measured by the unit becomes larger.

• Locating a hot Spot

To find a hot spot aim the thermometer outside the area of interest, then scan across with an up and down motion until you locate hot spot.

• Reminders

Not recommended for use in measuring shiny or polished metal surfaces (stainless steel, aluminum, etc.). See Emissivity

The unit cannot measure through transparent surfaces such as glass. It will measure the surface temperature of the glass instead.

Steam, dust, smoke, etc., can prevent accurate measurement by obstructing the unit's optics.

• Emissivity

Emissivity is a term used to describe the energy-emitting characteristics of materials. Most (90% of typical applications) organic materials and painted or oxidized surfaces have an emissivity of 0.95 (pre-set in the unit). Inaccurate readings will result from measuring shiny or polished metal surfaces. To compensate, cover the surface to be measured with masking tape or flat black paint. Allow time for the tape to reach the same temperature as the material underneath it. Measure the temperature of the tape or painted surface.

•Emissivity Values

Substance	Thermal Emissivity	Substance	Thermal Emissivity
Asphalt	0.90 to 0.98	Cloth (black)	0.98
Concrete	0.94	Human skin	0.98
Cement	0.96	Lather	0.75 to 0.80
Sand	0.90	Charcoal (powder)	0.96
Earth	0.92 to 0.96	Lacquer	0.80 to 0.95
Water	0.92 to 0.96	Lacquer (matt)	0.97
Ice	0.96 to 0.98	Rubber (black)	0.94
Snow	0.83	Plastic	0.85 to 0.95
Glass	0.90 to 0.95	Timber	0.90
Ceramic	0.90 to 0.94	Paper	0.70 to 0.94
Marble	0.94	Chromium oxides	0.81
Plaster	0.80 to 0.90	Copper oxides	0.78
Mortar	0.89 to 0.91	Iron oxides	0.78 to 0.82
Brick	0.93 to 0.96	Textiles	0.90

15.Maintenance

- Repairs or service are not covered in this manual and should only be carried out by qualified trained technician.
- Periodically, wipe the body with a dry cloth. Do not use abrasives or solvents on this instrument.
- For service, use only manufacturer’s specified parts.



InfraRed Thermometer User Manual





InfraRed Thermometer User Manual

Rev.090327

